

Universal TS Series

ROTARY POSITIVE DISPLACEMENT TWIN SCREW PUMP

FORM NO.: 95-03141 REVISION: 06/2017

READ AND UNDERSTAND THIS MANUAL PRIOR TO OPERATING OR SERVICING THIS PRODUCT.





ADDING A POWERFUL NEW TOOL TO YOUR MAINTENANCE PROGRAM

SPX FLOW has recently launched its SPX Connect App allowing users the ability to access product support information 24/7 using a smart device with internet access.

A quick scan of the product's QR code will provide you with immediate access to:

- Product Descriptions and General Operating Specifications
- Maintenance Manuals and Documentation
- Maintenance Videos and Product Animations
- Distributor Look Up Feature
- Submit Quote Requests

SPX FLOW is committed to providing you with innovative products and technologies to help keep your process flowing. **Plan your next scan and download the Free SPX Connect App today.**

To learn more about SPX Connect, contact SPX FLOW at 800.252.5200 or wcb@spxflow.com.



Waukesha Cherry-Burrell®





Declaration of Conformity for Pumps

SPX Flow US, LLC, 611 Sugar Creek Drive, Delavan, WI 53120, USA
herewith declares that the

pumps of the series

Universal TS

UTS 015, UTS 030, UTS 130, UTS 220

meet the requirements of the Directives 2006/42/EC (superseding 89/392/EEC and 98/37/EC) and ProdSG (superseding GPSG - 9.GPSGV).

For official inspections, SPX Flow Technology Rosista GmbH presents a technical documentation according to Appendix VII of the Machinery Directive, this documentation consisting of documents of the development and construction, description of measures taken to meet the conformity and to correspond with the basic requirements on safety and health, include an analysis of the risks, as well as an operating manual with safety instructions.

The conformity of the pumps is guaranteed.

Authorised person for the documentation:
SPX Flow Technology Rosista GmbH, Frank Baumbach,
Gottlieb-Daimler-Str. 13, D-59439 Holzwickede

May 17, 2017



Regional Eng Mgr, F&B Components

SPX FLOW, Inc.
611 Sugar Creek Road
Delavan, WI 53115 USA

Tel: (800) 252-5200 or (262) 728-1900
Fax: (800) 252-5012 or (262) 728-4904

E-mail: wcb@spxflow.com
Web site: www.spxflow.com

Information contained in this manual is subject to change without notice and does not represent a commitment on the part of SPX FLOW, Inc.. No part of this manual may be reproduced or transmitted in any form or by any means, electronic or mechanical, including photocopying and recording, for any purpose, without the express written permission of SPX FLOW, Inc..

Copyright © 2017 SPX Corporation.
All Rights Reserved.

Loctite® is a registered trademark of Henkel Corporation

Revision Date: 06/2017

Publication: 95-03141

Warranty	6
Shipping Damage or Loss	6
Warranty Claim	6
Safety	7
Warnings	8
Replacement Labels	9
Care of Component Materials	10
Stainless Steel Corrosion	10
Alloy 88	10
Aluminum	10
Elastomer Seal Replacement Following Passivation	10
Introduction	11
Pump Receiving	11
Intended Use	11
Equipment Serial Number	11
Certifications	11
Operating Parameters	12
Qualification Guidelines for Operating Staff	12
Installation	14
Important Safety Information	14
Lifting	14
Install Pump and Drive Unit	16
Direction of flow	17
Install Connections and Piping	17
Install Check Valves	18
Install Isolation Valves	19
Install Relief Valves	19
Inlet Side Strainers and Traps	20
Install Pressure Gauges	20
Seal Flush Connections	20
CIP (Clean-In-Place) Features	21
Check Coupling Alignment	21
Check Angular Alignment	22
Check Parallel Alignment	22
Check Belt and Chain Drive Alignment	22
Operation	23
Important Safety Information	23
Pre-Startup Checklist	23
Starting the Pump	24
Stopping the Pump	24
Maintenance	25
Important Safety Information	25
Lubrication	26
Oil Specification	26
Maintenance Inspections	26
Annual Maintenance	26
Cleaning	27
Fluid Head Disassembly	29
Remove cover	29

Remove screws	30
Remove seal cap and seal	32
Removing seal without removing body	33
Remove pump body	34
Double seal - remove seals	35
Single and double seal - remove seal carrier	36
Removing seal after body is removed	36
Fluid Head Assembly	38
Seal assembly	38
Installing seals before installing body	39
Install body	43
Installing seals after the body is installed	46
Seal cap assembly	47
Install screws	49
Screw nut assembly	51
Install cover	53
Gear Case Disassembly	55
Remove oil drain plugs and cover	55
Remove gear from short shaft	56
Remove gear from drive shaft	57
Remove shaft	58
Shaft disassembly	59
Gear Case Assembly	60
Shaft assembly	60
Install shafts in gear case	70
Install Bearing Retainers	72
Install Gears and Time Screws	75
Install gear on drive shaft	75
Install plugs, sight glass, eye bolts	77
Install gear on short shaft	78
Timing	80
Assemble and install gear case cover	84
Troubleshooting	89
Long Term Storage	93
Pump Dimensions	94
Pump Shaft Guards	95
Parts List	96
015-UTS Parts	96
030-UTS Parts	100
130-UTS Parts	104
130-UTS Parts	105
220-UTS Parts	108
Universal Twin Screw Seal Parts	113
Special Tools	114
Non-Marring Socket Tool for Screw Nuts	114
UTS Shaft Locking Tool	114
O-ring Removal Tool	114
Screw Blocking Tool	114
Gear Tools	114
Universal Twin Screw Maintenance Summary Reference Sheet	116
Universal Twin Screw Maintenance Summary Reference Sheet - Copy for optional removal	117

Warranty

LIMITED WARRANTY: Unless otherwise negotiated at the time of sale, SPX FLOW US, LLC (SPX FLOW) goods, auxiliaries and parts thereof are warranted to the original purchaser against defective workmanship and material for a period of twelve (12) months from date of installation or eighteen (18) months from date of shipment from factory, whichever expires first. If the goods or services do not conform to the warranty stated above, then as Buyer's sole remedy, SPX FLOW shall, at SPX FLOW's option, either repair or replace the defective goods or re-perform defective services. Third party goods furnished by SPX FLOW will be repaired or replaced as Buyer's sole remedy, but only to the extent provided in and honored by the original manufacturer's warranty. Unless otherwise agreed to in writing, SPX FLOW shall not be liable for breach of warranty or otherwise in any manner whatsoever for: (i) normal wear and tear; (ii) corrosion, abrasion or erosion; (iii) any good or services which, following delivery or performance by SPX FLOW, has been subjected to accident, abuse, misapplication, improper repair, alteration, improper installation or maintenance, neglect, or excessive operating conditions; (iv) defects resulting from Buyer's specifications or designs or those of Buyer's contractors or subcontractors other than SPX FLOW; or (v) defects resulting from the manufacture, distribution, promotion or sale of Buyer's products.

THE WARRANTIES CONTAINED HEREIN ARE THE SOLE AND EXCLUSIVE WARRANTIES AVAILABLE TO BUYER AND SPX FLOW HEREBY DISCLAIMS ANY OTHER WARRANTIES, EXPRESS OR IMPLIED, INCLUDING WITHOUT LIMITATION THE IMPLIED WARRANTIES OF MERCHANTABILITY AND FITNESS FOR A PARTICULAR PURPOSE. THE FOREGOING REPAIR, REPLACEMENT AND RE-PERFORMANCE OBLIGATIONS STATE SPX FLOW'S ENTIRE AND EXCLUSIVE LIABILITY AND BUYER'S EXCLUSIVE REMEDY FOR ANY CLAIM IN CONNECTION WITH THE SALE AND FURNISHING OF SERVICES, GOODS OR PARTS, THEIR DESIGN, SUITABILITY FOR USE, INSTALLATION OR OPERATIONS.

Shipping Damage or Loss

If equipment is damaged or lost in transit, file a claim at once with the delivering carrier. The carrier has a signed Bill of Lading acknowledging that the shipment has been received from SPX FLOW in good condition. SPX FLOW is not responsible for the collection of claims or replacement of materials due to transit shortage or damages.

Warranty Claim

Warranty claims must have a **Returned Material Authorization (RMA)** from the Seller or returns will not be accepted. Contact 800-252-5200 or 262-728-1900.

Claims for shortages or other errors must be made in writing to Seller within ten (10) days after delivery. This does not include transit shortage or damages. Failure to give such notice shall constitute acceptance and waiver of all such claims by Buyer.

Safety

READ AND UNDERSTAND THIS MANUAL PRIOR TO INSTALLING, OPERATING, OR SERVICING THIS EQUIPMENT

SPX FLOW recommends users of our equipment and designs follow the latest Industrial Safety Standards. At a minimum, these should include the industrial safety requirements established by:

1. Occupational Safety and Health Administration (OSHA)
2. National Fire Protection Association (NFPA)
3. National Electrical Code (NEC)
4. American National Standards Institute (ANSI)

⚠ WARNING

Severe injury or death can result from electrical shock, burn, or unintended actuation of equipment. Recommended practice is to disconnect and lockout industrial equipment from power sources, and release stored energy, if present. Refer to the National Fire Protection Association Standard No. NFPA70E, Part II and (as applicable) OSHA rules for Control of Hazardous Energy Sources (Lockout-Tagout) and OSHA Electrical Safety Related Work Practices, including procedural requirements for:

- Lockout-tagout
- Personnel qualifications and training requirements
- When it is not feasible to de-energize and lockout-tagout electrical circuits and equipment before working on or near exposed circuit parts

Before putting SPX FLOW equipment into operation, the operator shall analyze the application for all foreseeable risks, their likelihood to occur and the potential consequences of the identified risks as per ISO 31000 and ISO/IEC 31010 in their actual current version.

Locking and Interlocking Devices: These devices should be checked for proper working condition and capability of performing their intended functions. Make replacements only with the original equipment manufacturer's OEM renewal parts or kits. Adjust or repair in accordance with the manufacturer's instructions.

Periodic Inspection: Equipment should be inspected periodically. Inspection intervals should be based on environmental and operating conditions and adjusted as indicated by experience. At a minimum, an initial inspection within 3 to 4 months after installation is recommended. Inspection of the electrical control systems should meet the recommendations as specified in the National Electrical Manufacturers Association (NEMA) Standard No. ICS 1.3, Preventative Maintenance of Industrial Control and Systems Equipment, for the general guidelines for setting-up a periodic maintenance program.

Replacement Equipment: Use only replacement parts and devices recommended by the manufacturer to maintain the integrity of the equipment. Make sure the parts are properly matched to the equipment series, model, serial number, and revision level of the equipment.

Warnings and cautions are provided in this manual to help avoid serious injury and/or possible damage to equipment:

⚠ DANGER

Immediate hazards which WILL result in severe personal injury or death.

⚠ WARNING

Hazards or unsafe practices which COULD result in severe personal injury or death.

⚠ CAUTION

Hazards or unsafe practices which COULD result in minor personal injury or product or property damage.

Warnings

1. Read the instructions before installing the pump and starting it up. Always follow the guidelines for assembly in order to achieve optimum operational reliability.
2. Always check that the specifications of the motor and the motor control unit are correct, particularly in operating environments where there may be a risk of explosion.
3. Pumps should only be installed, disassembled, repaired and assembled by personnel trained in servicing pumps.
4. Always ensure that all electrical installation is carried out by qualified staff.
5. Never hose down or clean the electric motor directly with water or cleaning fluid. If the motor will be used in a washdown environment a washdown designed motor must be used.
6. Never dismantle the pump before the motor has been disconnected from the power supply. Remove the fuses and disconnect the cable from the motor terminal box.
7. Never dismantle the pump until the isolating valves on the suction and discharge side have been closed and the immediate pipe system has been drained. If the pump is used for hot and/or hazardous fluids, special precautions must be taken. In such cases follow the local regulations for personal safety when working with these products.
8. Always ensure that all pipe connections have been fitted and tightened properly before the pump is started. If the pump is used for hot and/or hazardous liquids, take special care: follow the local regulations for personal safety when working with these products.
9. Always wear personal protective equipment according to the requirements established by OSHA, NFPA, NEC (See page 7).
10. Always remove all assembly and auxiliary tools from the pump before starting it up.
11. Make sure product lines and power cables are laid in suitable guides/trays.
12. Always ensure that no debris of any kind is present in the pump.
13. Always ensure that the pump and the motor shafts are properly aligned.
14. Always ensure that the suction and discharge valves isolating the pump are fully open before starting the pump.
15. Never close or obstruct the outlet of the pump as the pressure in the system will increase above the specified maximum pressure of the pump and cause damage to the pump.
16. There are rotating parts in the pump. Never put hands or fingers into a pump while it is in operation.
17. The pump components and piping may contain sharp edges. Handle the screws carefully because edges may be sharp. Wear gloves while installing and servicing the pump to help avoid injuries from these hazards.
18. Never touch the gear case during operation. The surface temperature of the gear case can get above 160°F (71°C) when running at 1000-3500 RPM. The pump cover and body may be cold or hot depending on the product (CIP at 190°F (88°C) or 300°F (149°C) product, for example).
19. Never touch the motor or motor shroud (if supplied) during operation, as it can become very hot.
20. When moving the pump, use appropriate lifting devices. Attach lifting devices to the eye bolts on the gear case; the gear case has holes for attaching lifting eye bolts. The 130 and 220 UTS pumps have a third lifting point on the body (130) and cover (220). Always use securely fitted lifting straps when lifting with a crane or similar lifting gear. See “Lifting” on page 14.
21. Never drop parts on the floor.
22. Never exceed the maximum temperature specified under “Operating Parameters” on page 12.
23. Never exceed 375 psi / 25.8 bar maximum operating pressure.
24. Guards should be used when applicable. See page 16 and page 23.
25. Make sure to keep the work area clear of machine parts, tools, product lines, foreign materials, and power cables to avoid potential hazards.

Replacement Labels

⚠ WARNING

The following labels are installed on your equipment. If these labels are removed or become unreadable, contact SPX FLOW customer service at 800-252-5200 or 262-728-1900, and refer to the part numbers below.

Application Instructions

Apply to a clean, dry surface. Remove the backing from the label, place it in proper position, protect it with a cover sheet and burnish it. (A soft rubber roller also may be used to press the label into place.) Apply all labels to be readable from the front of the pump.

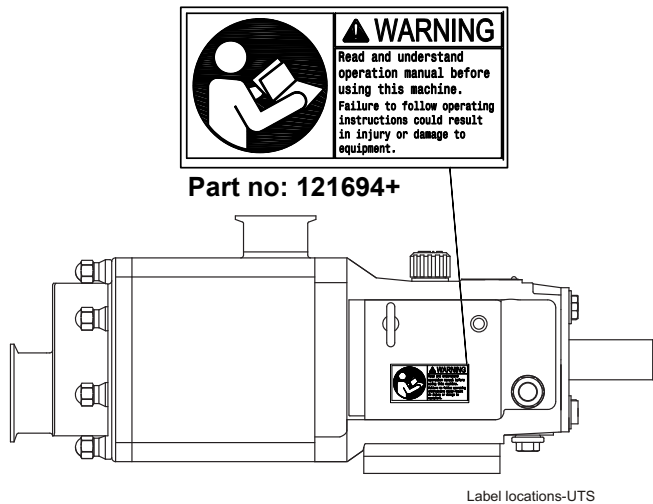
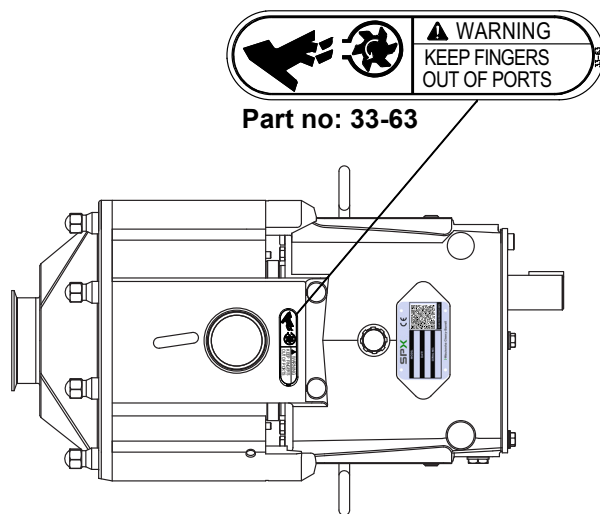

The labels above are affixed to the pumps as shown. (130-UTS pump is shown. Label placement is similar on other sizes.) If the pump is mounted on a bracket, the “Read and understand operation manual” label is placed on the arm of the bracket.

IMPORTANT

1. Pump and Drive are factory aligned.
2. Recheck alignment after installation and before start-up.
3. Recheck alignment periodically, to maximize service life.

33-95

Part no: 33-95
 This label is supplied on base packages, on the side of the gear case.

IMPORTANT

To avoid damage to the shaft seals and/or pump parts:

DO NOT START this pump unless Seal Flush has been installed and is turned ON.

PD100-236a

Part no: 112446+
 This label is supplied with pumps with double mechanical seals. It is attached to the eye bolt.

Care of Component Materials

NOTE: SPX FLOW recommends the use of an FDA-approved anti-seize compound on all threaded connections.

⚠ WARNING

Failure to comply with the Care of Component Materials could lead to bodily injury.

Stainless Steel Corrosion

Corrosion resistance is greatest when a layer of oxide film is formed on the surface of stainless steel. If film is disturbed or destroyed, stainless steel becomes much less resistant to corrosion and may rust, pit or crack.

Corrosion pitting, rusting and stress cracks may occur due to chemical attack. Use only cleaning chemicals specified by a reputable chemical manufacturer for use with 300 series stainless steel. Do not use excessive concentrations, temperatures or exposure times. Avoid contact with highly corrosive acids such as hydrofluoric, hydrochloric or sulfuric. Also avoid prolonged contact with chloride-containing chemicals, especially in presence of acid. If chlorine-based sanitizers are used, such as sodium hypochlorite (bleach), do not exceed concentrations of 150 ppm available chlorine, do not exceed contact time of 20 minutes, and do not exceed temperatures of 104°F (40°C).

Corrosion discoloration, deposits or pitting may occur under product deposits or under gaskets. Keep surfaces clean, including those under gaskets or in grooves or tight corners. Clean immediately after use. Do not allow equipment to set idle, exposed to air with accumulated foreign material on the surface. Corrosion pitting may occur when stray electrical currents come in contact with moist stainless steel. Ensure all electrical devices connected to the equipment are correctly grounded.

Alloy 88

Waukesha Alloy 88 is the standard rotor material for Universal I, Universal II, Universal TS, Universal Lobe, Universal 420/520 and 5000 Series Rotary PD pumps. This alloy was developed specifically for corrosion resistance and close operating clearance requirements of high performance rotary positive displacement pumps. Alloy 88 is a nickel based, corrosion-resistant, non-galling or seizing material. The ASTM designation is A494 Grade CY5SnBiM (UNS N26055), and the material is listed in the 3-A Sanitary Standards as acceptable for product contact surfaces.

The corrosion resistance of Alloy 88 is approximately equal to AISI 300 Series Stainless Steel. However, Alloy 88 has limited resistance to certain aggressive chemicals that may be commonly used in contact with AISI 300 Series Stainless Steel.

Do not use Alloy 88 in contact with nitric acid. Nitric acid is commonly used to passivate new installations of stainless steel equipment. Do not allow nitric acid based passivation chemicals to contact Alloy 88 rotors. Remove the rotors during passivation and use a separate pump to circulate the passivation chemicals. Also, if nitric acid-based CIP cleaning chemicals are used, remove the rotors prior to CIP cleaning and clean them separately by hand in a mild detergent. If you have questions regarding other aggressive chemicals, please contact SPX FLOW Application Engineering for assistance.

Aluminum

Aluminum is a "soft" metal; hard sharp objects will damage the surface. The Hard Coat Anodized Sealed surface provides corrosion and wear protection. Use caution when installing and removing the cover while servicing the pump. If the surface of the aluminum cover is damaged, replace with a new cover. The gear shrouds are not anodized, but are located inside the oil sump. Should they become damaged during servicing, replace with new parts.

Elastomer Seal Replacement Following Passivation

Passivation chemicals can damage product contact areas of this equipment. Elastomers (rubber components) are most likely to be affected. Always inspect all elastomer seals after passivation is completed. Replace any seals showing signs of chemical attack. Indications may include swelling, cracks, loss of elasticity or any other noticeable changes when compared with new components.

Introduction

Pump Receiving

⚠ DANGER

The pump contains internal moving parts. DO NOT put hands or fingers into the pump body ports or drive area at any time during operation. To avoid serious injury, DO NOT install, clean, service, or repair the pump unless all power is off and locked out and the pump is de-pressurized.

All ports are covered at the factory to keep out foreign objects during transit. If covers are missing or damaged, remove the pump cover (if damaged) and thoroughly inspect the fluid head. Be sure that the pumping head is clean and free of foreign material before rotating the shaft.

The Waukesha Cherry-Burrell brand Universal Twin Screw pump uses a screw style rotor. The terms “Screw” and “Rotor” can be used interchangeably when referring to the screw style rotors.

Each standard Waukesha Cherry-Burrell brand pump is shipped completely assembled and lubricated. Review “Operation” on page 23 before operating the pump.

Intended Use

The Waukesha Cherry-Burrell brand Universal Twin Screw pump is exclusively intended for pumping liquids, especially in food and beverage installations.

Refrain from using the pump in a manner which exceeds the scope and specifications stated below.

Any use exceeding the margins and specifications set forth is considered to be not intended.

SPX FLOW is not liable for any damage resulting from such activities. The user bears the full risk.

⚠ WARNING

Improper use of the pump leads to:

- damage
- leakage
- destruction
- potential failures in the production process

Equipment Serial Number

All Waukesha Cherry-Burrell brand pumps are identified by a serial number on the gear case nameplate, which is stamped on the pump body and cover.

Certifications

3-A

See the 3-A website for current certificates: www.3-a.org/3-A-Symbol/Search-Database-of-Current-Certificates.

Certificate Number 29 covers all SPX FLOW Centrifugal and Rotary Pumps. You can search using: Certificate Number 29, Company Name "SPX Flow US, LLC," or Standard Number 02-__. The 3-A Standard for fittings is 63-___. ("__" indicates the current revision.)

Only designs meeting 3-A Standards are 3-A certified.

Operating Parameters

UTS Model	Screw Pitch (mm)			Maximum Nominal Capacity (gpm)	Horizontal Port (Cover)	Vertical Port (Body)	Max. Pressure Range	Max. RPM	Temp.*
	Displacement (gal./revolution)								
015	16.5	33	44	0.10 – 70	2"	1.5"	375 psi / 25.8 bar	3500	Max. Gearcase temp: 180°F / 82°C Max. product temp: 300°F / 149°C
	0.016	0.031	0.041						
030	16.8	28	42	0.40 – 130	2.5"	2"		3100	
	0.030	0.050	0.076						
130	36.7	55	73.4	4.00 – 350	4"	2.5"	2500		
	0.119	0.178	0.239						
220	45	60	90	40.0 – 880	4" or 6"	4" or 6"	2000		
	0.301	0.44	0.605						

* Max Oil temperature of 180°F (82°C) requires the pump to be shut down, and allowed to cool off. The surface temperature of the gear case may exceed 160°F (71°C). Contact SPX FLOW Application Engineering for higher pressure or higher temperature applications.

⚠ DANGER

Operating the pump outside the stated operating parameters may result in severe personal injury or death.

Qualification Guidelines for Operating Staff

Definitions

Operator

A person who is capable of handling the installation, interior, operation, warnings, cleaning, repair or transportation of the machine.

Trained person

A person who is instructed in the tasks given and the possible dangerous situation that may occur. The person is also aware of the protection installations and measures.

Skilled worker

A person who based upon his or her background and due to his or her knowledge, is able to perform the tasks, and has an appropriate knowledge of the provisions given.

Table 1: Qualification Guidelines for Operating Staff

Phase of Life	Task Example	Prerequisite for the operating staff	
		Trained person	Skilled worker
Transport	Lift	x	
	Loading	x	
	Unloading	x	
Assembly and Installation/ Commissioning	Assembly/fastening of the machine		x
	Connection to the electric grid		x
	Filling of lubricant to drive motors	x	
Operation	Startup	x	
	Controlling	x	
	Surveillance	x	
	Shutdown	x	
Cleaning, Maintenance	Cleaning	x	
	Refilling of lubricants	x	
	Disconnection from energy supply	x	
	Assembly/Disassembly of parts	x	
Troubleshooting	Disconnection from energy supply	x	
	Troubleshooting	x	
	Assembly/Disassembly of parts	x	
	Repair	x	
Dismounting/Unplugging from plant	Removal of energy supply	x	
	Dismount		x
	Lift		x
	Loading		x
	Unloading		x

Installation

Important Safety Information

⚠ DANGER

The pump contains internal moving parts. DO NOT put hands or fingers into the pump body ports or drive area at any time during operation. To avoid serious injury, DO NOT install, clean, service, or repair the pump unless all power is off and locked out and the pump is de-pressurized.

⚠ WARNING

The pump components and piping may contain sharp edges. Handle the screws carefully because edges may be sharp. Wear gloves while installing and servicing the pump to help avoid injuries from these hazards.

⚠ CAUTION

Maintenance should be performed only by trained personnel. See "Qualification Guidelines for Operating Staff" on page 12.

Lifting



Figure 1 - Lifting location - 015, 030-UTS

⚠ CAUTION

When moving the pump, use appropriate lifting devices. Always use securely fitted lifting straps/chains when lifting with a crane or similar lifting gear.

⚠ WARNING

Do not stand underneath the pump while it is being lifted.

Attach lifting devices as shown:

- On the 015-UTS and 030-UTS (Figure 1 and Figure 2), attach straps/chains to the two eye bolts on either side of the gear case, and slide a strap under the horizontal port on the cover.



Figure 2 - Lifting location detail - 015, 030-UTS



Figure 3 - Lifting location - 130, 220-UTS

- On the 130-UTS and 220-UTS (Figure 3), attach lifting straps/chains to the two eye bolts on either side of the gear case, and to the single vertical eye bolt located in front of the vertical port.
- Unit orders (not pictured) have holes for attaching eye bolts on the four corners of the base. Attach straps/chains to all four eye bolts.

Model	Weight
015-UTS	87 lb (39 kg)
030-UTS	160 lb (73 kg)
130-UTS	385 lb (175 kg)
220-UTS	750 lb (340 kg)

Install Pump and Drive Unit

⚠ CAUTION

Install the pump and piping system in accordance with local codes and restrictions. Practices described in this manual are recommended for optimum performance.

⚠ CAUTION

The motor must be installed by qualified personnel, e.g., a licensed electrician.

All system equipment, such as motors, sheaves, drive couplings, speed reducers, etc., must be properly sized to ensure satisfactory operation of your Waukesha Cherry-Burrell brand pump within its limits. Customer-supplied motors should have a basic level of safety to prevent electrical hazards, and should be dealt with in accordance with the manufacturer's instructions.

In a typical installation configuration, the pump and drive unit are mounted on a common base plate. The unit can be installed in any of the arrangements shown in Figure 4 through Figure 7.

NOTE: The gap between the pump body and gearcase is required for 3-A sanitary standards.

NOTE: When installing a unit as shown in Figure 7, level the unit before installing the bolts.

The shaded area in Figure 4 through Figure 7 indicates the guard location.

See "Pump Shaft Guards" on page 95.

⚠ WARNING

Full guards must be installed to isolate operators and maintenance personnel from rotating components.

Guards are provided as part of a complete pump and drive package and are selected by SPX FLOW Engineering for the pump, base, and motor ordered. Do not modify the guard provided by SPX FLOW. If the guard provided by SPX FLOW is lost, contact SPX FLOW Customer Service and provide your order number or PO number of the pump to order a correctly-sized replacement guard.

If the pump was not purchased as a unit, it is the responsibility of the customer to ensure proper guarding. Refer to your local regulations for guidance.

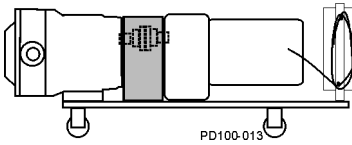

Figure 4 - Portable Base

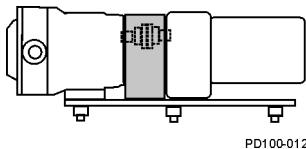

Figure 5 - Adjustable Leg Base

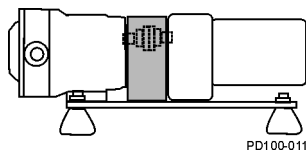

Figure 6 - Leveling and/or Vibration Isolation Pads

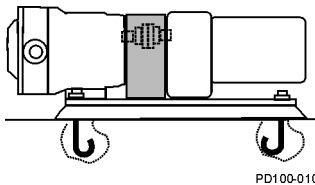

Figure 7 - Permanent Installation on Foundation

Direction of flow

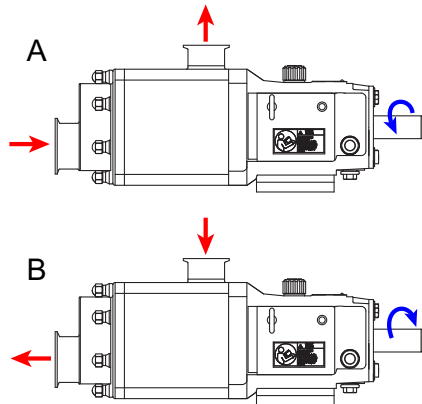

Figure 8 - Direction of flow

The default direction of flow is from the horizontal port (in the front of the cover) to the vertical port, with the drive shaft running clockwise as viewed facing the cover of the pump. See view A in Figure 8.

To change the direction of flow, run the drive shaft in the opposite direction (counter-clockwise), as viewed facing the cover of the pump. See view B in Figure 8.

Install Connections and Piping

⚠ CAUTION

These pumps are positive displacement design and will be severely damaged if operated with closed valves in discharge or inlet lines. The pump warranty is not valid for damages caused by a hydraulic overload from operation or start-up with a closed valve in the system.

Piping Support

To minimize forces exerted on the pump, support all piping to the pump independently with hangers or pedestals. Such forces can cause misalignment of the pump parts and lead to excessive wear of screws, bearings, and shafts.

Figure 9 shows typical supporting methods used to independently support each pipe, reducing the weight effect of piping and fluid on the pump.

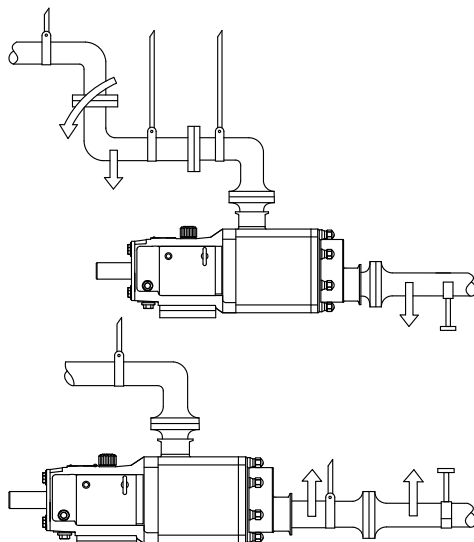

Figure 9 - Piping Support

⚠ WARNING

Do not exceed 50 lb (22.7 kg) load on the pump inlet or discharge ports. Exceeding this limit may cause damage to the pump

Expansion Joints

Thermal expansion of piping can cause tremendous forces. Use thermal expansion joints to minimize these forces on the pump.

Flexible joints can be used to limit transmission of mechanical vibration. Ensure that the free ends of any flexible connections in the system are anchored.

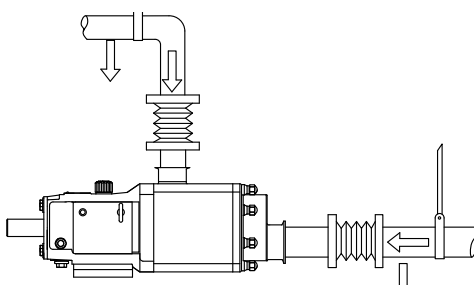

Figure 10 - Flexible Connections and Supports

Inlet Piping

Install the pump below the supply liquid level to reduce the air in the system by flooded suction, to prevent the pump from becoming air-bound (Figure 11).

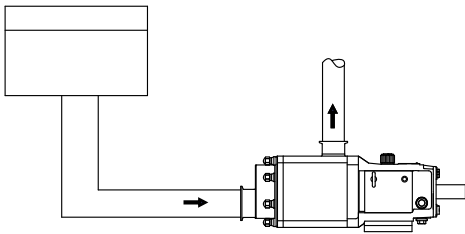

Figure 11 - Pump Below Supply (recommended)

If the pump is installed above the supply liquid level, the piping on the inlet side must slope up toward the pump, preventing air pockets in the pipes (Figure 12).

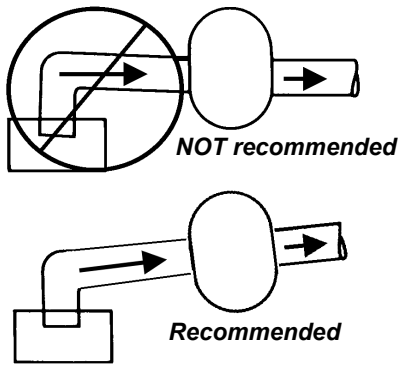

Figure 12 - Piping Slope

Install Check Valves

Inlet Side on Lift Applications

Use check valves to keep the inlet line full, particularly with low-viscosity fluids (Figure 13).

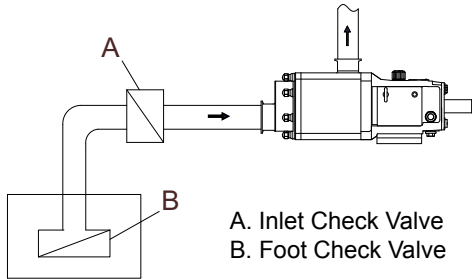
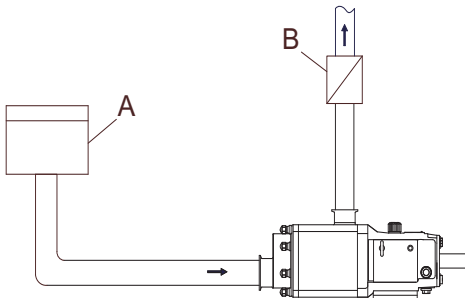

Figure 13 - Inlet Check Valve

Discharge Side

For systems with liquid under a vacuum, install a check valve on the discharge side of the pump. The check valve prevents backflow (air or fluid) to aid in the initial start-up by minimizing the required differential pressure supplied by the pump to start the flow (Figure 14).



- A. Closed Tank - produces vacuum on liquid (Low Absolute Pressure)
- B. Check Valve (outlet)

Figure 14 - Discharge Check Valve

Install Isolation Valves

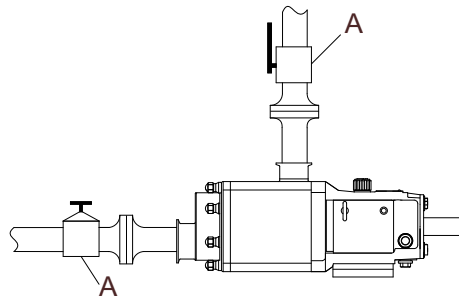

Figure 15 - Isolation Valves

Isolation valves permit pump maintenance and safe pump removal without draining the system (Figure 15, item A).

NOTE: Make sure the inlet flow is not restricted. Do not start the pump deadheaded, e.g., operated with no flow through it.

Install Relief Valves

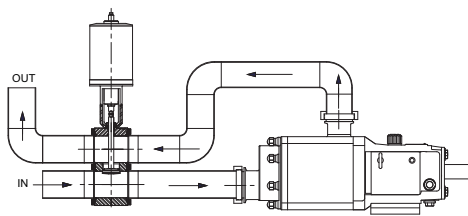

Figure 16 - WR63 Reverse-Acting Over-Pressure Relief Valve

Install relief valves to protect the pump and piping system against excessive pressure. We recommend installing an external relief valve designed to bypass fluid from the pump outlet to the inlet side of the system (See Figure 16, Figure 17, and Figure 18).

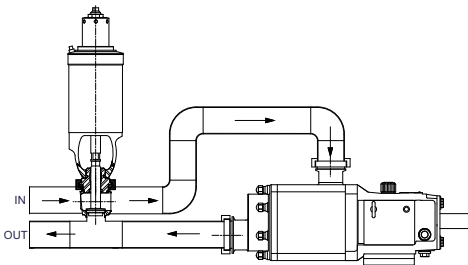

Figure 17 - WR61C Air-to-Raise Valve with Adjustable-Spring Actuator

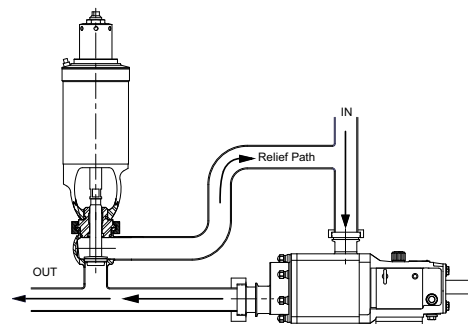
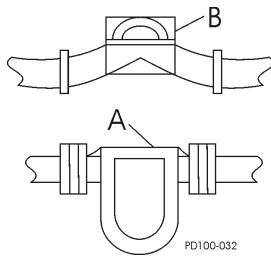

Figure 18 - WR61T 4RHAR Valve

Inlet Side Strainers and Traps



A. Strainer B. Magnetic Trap

Figure 19 - In-line Strainers and Traps

Inlet side strainers and traps (Figure 19, items A and B, respectively) can be used to prevent foreign matter from damaging the pump. Select carefully to prevent cavitation caused by the restriction of the inlet. If inlet strainers are used, they must be serviced regularly to prevent clogging and flow stoppage.

Install Pressure Gauges

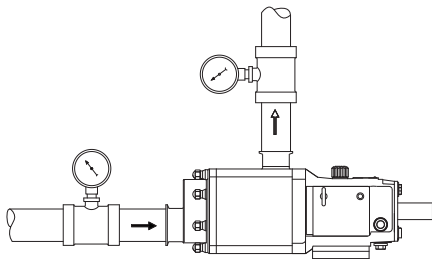

Figure 20 - Pressure and Vacuum Gauges

Pressure and vacuum gauges provide valuable information about pump operation (Figure 20). Wherever possible, install the gauges to help provide information on the following:

- Normal or abnormal pressures
- Indication of flow
- Changes in pump condition
- Changes in system conditions
- Changes in fluid viscosity

Seal Flush Connections

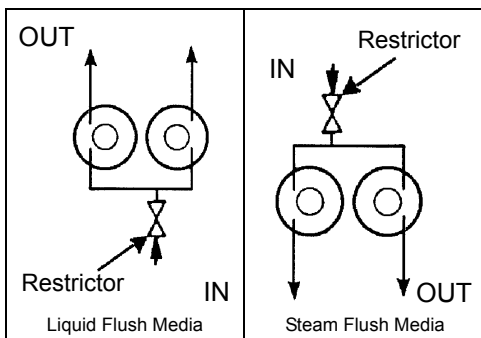

Figure 21 - Flush Piping Setup

Pumps with double seals require flushing. The flush media (water or lubricating fluid compatible with the product) must be connected and flowing whenever the pump is operated.

WARNING

Operating the pump without flush will damage the seal and pump parts due to excess heat from dry running.

Pump bodies have 4 1/8-inch female pipe thread (NPT) flush connections located near the bottom and top of the body.

NOTE: If steam is used as a flush media, connect the inlet at the upper connection, and the outlet at the lower connection to ensure condensation removal.

If steam condensate is used as a flush media, connect the inlet at the lower connection, and the outlet at the upper connection.

1. Connect the flush inlet to the lower connection, and outlet to upper connection to flood the flush area completely.
2. Connect the flush outlet for unrestricted flow to the drain.
3. Use cool, filtered flush media to obtain maximum service life of the seal components. If the pumped product is sticky or solidifies at room temperature, use warm or hot flush media.
4. Install a pressure reducing valve and flow control valve (needle valve) on the flush supply line. Set the supply pressure at a maximum of 30 psi (2 bar) and adjust the flow rate to approximately 1/4 gpm (more for high temperature applications).
5. Also install a solenoid valve in the flush supply and wire it in series with the motor starter to provide an automatic start/stop of the flush media flow before the motor turns on and after the motor turns off.

CIP (Clean-In-Place) Features

Universal Twin Screw pumps function as a CIP pump and a product pump in one. Run the pump at fast speeds (1300-3500 RPM) for CIP; slower speeds for product. These pumps are designed to provide complete access of the CIP solutions to all product contact surfaces.

Standard CIP features include

- Free draining cover
- Custom cover gasket to exclude small particulates (seeds)

Guidelines

Use the following guidelines when designing and installing the CIP system to ensure successful cleaning:

⚠ CAUTION

In order to avoid temperature shock after the introduction of hot CIP fluid, stop the pump prior to, or immediately after filling with hot CIP fluid. Once the hot CIP fluid has filled the pumphead, allow 15 minutes for the pump fluid components to thermally expand, then re-start the pump.

- Ensure that the velocity rate of CIP solutions is adequate to clean the entire circuit. For most applications, a velocity of 5 ft/sec is sufficient. For the CIP solution to achieve the proper velocity, the pump drive must have enough speed range and horsepower. The required inlet pressure also must be satisfied.
- Ensure that a differential pressure is created across the pump. Differential pressure will push CIP solutions through close-clearance areas of the pump, resulting in better cleaning action. The high pressure side may be either the inlet or outlet side. 30 psi (2 bar) differential pressure is adequate for most applications. For difficult cleaning applications, higher pressure or longer cleaning cycles may be required.
- If the Universal Twin Screw (UTS) pump is not the pump being used for CIP, the UTS pump must still be operated during CIP to increase turbulence and cleaning action within the pump.

Check Coupling Alignment



Figure 22 - Lovejoy Coupling



Figure 23 - T.B. Woods® Coupling

Pumps and drives ordered from the factory and mounted on a common base plate are aligned before shipment. Alignment **must** be re-checked after the complete unit has been installed and piping completed. Periodic re-checking is advisable during the pump service life.

- SPX FLOW recommends using a flexible coupling to connect the drive to the pump. Several different types are available, including couplings with slip or overload provisions. SPX FLOW provides Lovejoy (Figure 22) or T.B. Woods® (Figure 23) couplings unless otherwise specified when ordering. Flexible couplings can be used to compensate for end play and small differences in alignment.
- Align the pump and drive shaft as closely as possible:
 - Pump and Drive are factory aligned.
 - Re-check alignment after installation and before start-up.
 - Re-check alignment periodically, to maximize service life.

Check Angular Alignment

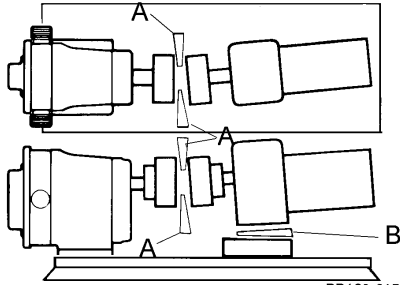

Figure 24 - Check Angular Alignment

1. Using feeler gauges or taper gauges (Figure 24, items A and B), check the alignment at four points every 90 degrees around the coupling; **adjust to equal dimension at all points.**
2. Set the space between the coupling halves to the manufacturer's recommended distance.
3. Install shims to bring the system into alignment.

Check Parallel Alignment

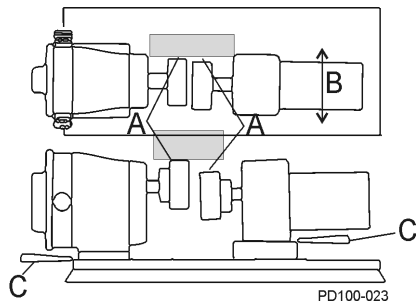

Figure 25 - Check Parallel Alignment

1. Check both the horizontal and vertical alignment of the pump and drive using a straight edge.
2. Using a feeler gauge at location "A" in Figure 25, determine the direction and amount of movement needed (Figure 25, item B).
3. If necessary, shim at location "C" and/or move drive as needed.

Check Belt and Chain Drive Alignment

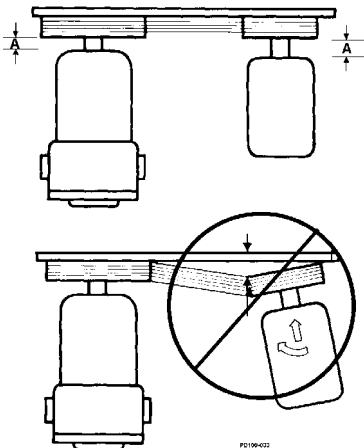

Figure 26 - Aligning Belt and Chain Drives

Use a straight edge to visually check the belt or chain alignment. Keep the shaft distance to a minimum (Figure 26, item A).

After the piping is complete and before the belts are installed, manually turn the pump shaft to ensure it turns freely.

Operation

Important Safety Information

⚠ DANGER

The pump contains internal moving parts. DO NOT put hands or fingers into the pump body ports or drive area at any time during operation. To avoid serious injury, DO NOT install, clean, service, or repair the pump unless all power is off and locked out and the pump is de-pressurized.

⚠ WARNING

The pump components and piping may contain sharp edges. Handle the screws carefully because edges may be sharp. Wear gloves while installing and servicing the pump to help avoid injuries from these hazards.

⚠ CAUTION

Maintenance should be performed only by trained personnel. See “Qualification Guidelines for Operating Staff” on page 12.

⚠ CAUTION

These pumps are positive displacement design and will be severely damaged if operated with closed valves in the discharge or inlet lines. The pump warranty is not valid for damages caused by a hydraulic overload from operation or start-up with a closed valve in the system.

Pre-Startup Checklist

⚠ CAUTION

The motor must be installed by qualified personnel, e.g., a licensed electrician.

⚠ CAUTION

Consult the motor or VFD manufacturer's manual for setup, operation, disassembly, and troubleshooting of the motor or VFD, or contact the manufacturer.

⚠ CAUTION

Do not use this pump to flush a newly-installed system. Severe damage may occur to the pump and system if the pump is used to flush the system.

⚠ WARNING

Full guards must be installed to isolate the operators and maintenance personnel from the rotating components. Guards are provided as part of a complete pump and drive package. See page 16 and page 95.

⚠ WARNING

Do not start a pump with seal flush unless the seal flush is installed and turned on.

1. Ensure that the pump is correctly installed as described in “Installation” on page 14. Review “Install Relief Valves” on page 19 and install relief valves as needed.
2. Check the coupling alignment. See “Check Coupling Alignment” on page 21.
3. Ensure that the pump and piping are clean and free of foreign material such as welding slag, gaskets, etc.
4. Ensure that all piping connections are tight and leak-free. Where possible, check the system with non-hazardous fluid.
5. Ensure that the pump and drive are lubricated. See “Lubrication” on page 26.
6. Ensure that all guards are in place and secure.
7. Double mechanical seals require adequate supply and flow of clean flushing fluids.
8. Ensure that all valves are open on the discharge side and a free flow path is open to the destination.
9. Ensure that all valves are open on the inlet side and fluid can fill the pump. A flooded suction installation is recommended.
10. Check the direction of pump and drive rotation to ensure that the pump will rotate in the proper direction. See “Direction of flow” on page 17.

Starting the Pump

⚠ WARNING

Keep a safe distance (1.6 ft/.5 m) away from the pump during startup.

⚠ CAUTION

The motor must be installed by qualified personnel, e.g., a licensed electrician.

⚠ CAUTION

In order to avoid temperature shock after the introduction of hot product, stop the pump prior to, or immediately after filling with hot product. Once the hot product has filled the pumphead, allow 15 minutes for the pump fluid components to thermally expand, then re-start the pump.

1. Start the pump drive. Where possible, start at a slow speed or jog.
2. For sanitary applications, sanitize the pump per customer requirements before putting the pump into service.
3. Check to make sure that the liquid is reaching the pump. If pumping does not begin and stabilize, check “Troubleshooting” on page 89.

Stopping the Pump

⚠ WARNING

Keep a safe distance (1.6 ft/.5 m) away from the pump during shutdown.

⚠ CAUTION

The motor must be installed by qualified personnel, e.g., a licensed electrician.

1. Shut off the power to the pump drive.
2. Shut off the supply and discharge lines.

Maintenance

Important Safety Information

⚠ DANGER

The pump contains internal moving parts. DO NOT put hands or fingers into the pump body ports or drive area at any time during operation. To avoid serious injury, DO NOT install, clean, service, or repair the pump unless all power is off and locked out and the pump is de-pressurized.

⚠ WARNING

The pump components and piping may contain sharp edges. Handle the screws carefully because edges may be sharp. Wear gloves while installing and servicing the pump to help avoid injuries from these hazards.

⚠ WARNING

Never touch the gear case during operation. The surface temperature of the gear box can get above 160°F (71°C) when running at 1000-3500 RPM.

⚠ CAUTION

Maintenance should be performed only by trained personnel. See "Qualification Guidelines for Operating Staff" on page 12.

⚠ CAUTION

Make sure to keep the work area clear of machine parts, tools, product lines, foreign materials, and power cables to avoid potential hazards.

⚠ CAUTION

Make sure appropriate lighting is available: at least 1000 lux, independent of daylight and weather conditions.

⚠ CAUTION

Before carrying out any maintenance and repair work on cold components, ensure that the machine parts in question are sufficiently heated. The contact temperature of accessible machine parts must not be lower than those in the EN ISO 13732-1.

Before detaching port connections to the pump:

- Close the suction and discharge valves.
- Drain the pump and clean or rinse, if necessary.
- Disconnect or shut off the electrical supply and lock out all power.

Lubrication

Table 3: Lubrication Quantities

UTS Model	Oil Capacity
015	110 ml / 3.7 oz
030	216 ml / 7.3 oz
130	525 ml / 17.8 oz
220	1575 ml / 53.3 oz

Drive

Refer to the manufacturer's manual shipped with the drive for proper drive lubrication and frequency.

Gears and bearings

Gears and bearings are factory-lubricated with gear oil at the quantity shown in Table 3. **First oil change at 250 hours, then every 2000 hours, depending on the operating conditions.** *Aggressive washdown or extreme running conditions may require more frequent lubrication intervals.*

When the pump is not running, the oil level is correct when the oil level is visible in the sight glass.

When the pump is running, the oil level may be difficult to see and may appear cloudy. Universal TS pumps are shipped with the oil level at or slightly above the center of the sight glass.

Oil Specification

Standard: Synthetic Mobil SHC 629-150, part no. 139215+

Food Grade: Synthetic Mobil SHC Cibus-150, part no. 139684+

Maintenance Inspections

⚠ DANGER

The pump contains internal moving parts. DO NOT put hands or fingers into the pump body ports or drive area at any time during operation. To avoid serious injury, DO NOT install, clean, service, or repair the pump unless all power is off and locked out and the pump is de-pressurized.

Detecting wear in the early stages can reduce repair costs and down time. A simple "look-feel" inspection of the pump during breakdown cleaning is recommended to detect signs of trouble at an early stage.

A detailed maintenance inspection should be scheduled annually. See "Annual Maintenance" on page 26.

Refer to the "Maintenance Inspection Chart" on page 28 for possible causes and solutions to common issues discovered during inspection.

Annual Maintenance

⚠ DANGER

The pump contains internal moving parts. DO NOT put hands or fingers into the pump body ports or drive area at any time during operation. To avoid serious injury, DO NOT install, clean, service, or repair the pump unless all power is off and locked out and the pump is de-pressurized.

At least annually, perform the procedures and corrective measures outlined in "Maintenance Inspections" on page 26, in addition to the following preventive maintenance:

- Remove the gear cover and inspect the gears for wear, backlash and looseness. Check the gear retaining nuts. If they are loose, replace them with new nuts. Do not re-torque the existing nut as it is one-time use only. The gear case cover gasket is designed to compress when the back cover bolts are torqued. If you are re-installing a back cover that has previously been torqued down, replace the gear case cover gasket.
- Review the performance record on the pump, and check the radial clearances to determine wear and effect on performance. Adjustment to the operating speed can compensate for wear in some applications.

Cleaning

Determine the pump cleaning schedule on-site for materials being processed and plant maintenance schedule. See “CIP (Clean-In-Place) Features” on page 21.

To disassemble the fluid head, see “Fluid Head Disassembly” on page 29. Remove and clean the cover gasket, pump seals, and the screw nut assembly. Inspect and replace them as necessary.

NOTE: *Always replace the screw nut O-rings, seal cap O-rings, and seal carrier O-rings when reassembling the pump. If the area behind these seals becomes soiled, contact SPX FLOW Application Engineering for a specific cleaning and sanitizing procedure validated to remove bacteria. If a chlorine solution (200 ppm available chlorine) is used, it should leave no residual deposits which would remain in the pump.*

Acid cleaners have a much higher metal corrosion rate and pump parts should remain in acid cleaning solutions no longer than necessary. Any strong inorganic mineral-based acids that are harmful to your hands would be harmful to pump parts. See “Care of Component Materials” on page 10.

In applications where material can harden in the pump during shutdown, a CIP cleaning, flush or disassembly of the fluid head and manual cleaning is strongly recommended.

Maintenance Inspection Chart

Problem	Possible Causes	Possible Solutions
Screw flank contact or Screw OD to bore contact.	Hard object jammed into screws and twisted shafts. Worn bearings. Loose screw nut(s). Belleville-style washer(s) on backwards. Axial clearances not even. Worn bearings.	Replace shafts. Install strainers if necessary. Check and replace gears if necessary. Replace bearings Torque screw nut(s) properly. Install belleville-style washers correctly. Verify axial clearances are even. Check and replace bearings. Reset.
Worn screw or shaft spline(s).	Loose screw nut(s). Belleville-style washer(s) on backwards. Timing is off.	Replace screws or shafts. Torque screw nut(s). See page 87. Install belleville-style washer(s) correctly.
Worn screw end or shaft shoulder.	Loose screw nut(s). Belleville-style washer(s) on backwards. Screws slammed against shoulder when installed.	Torque screw nut(s). See page 87. Install belleville-style washer(s) correctly. Replace screws and shafts or adjust screw timing to maintain proper axial clearances.
Sharp edged shaft shoulder.	Loose screw nut(s). Belleville-style washer(s) on backwards. Screws slammed against shoulder when installed. Axial clearances not even.	Torque screw nut(s). See page 87. Install belleville-style washer(s) correctly. Remove sharp edge with file to prevent cutting shaft o-ring. Verify axial clearances are even.
Gear backlash.	Lack of lubrication. Excessive hydraulic loads. Loose gear locknut. Worn gears. Worn gear key.	Check lubrication level and frequency. Reduce hydraulic loads. Torque locknuts to specified torque values. See page 87. Check and replace gears if necessary. Inspect gear key, shaft keyway and shaft, replace if necessary.
Worn or broken gear teeth.	Lack of lubrication. Excessive hydraulic loads. Loose gear locknut.	Check lubrication level and frequency. Reduce hydraulic loads. Torque locknuts to specified torque values. See page 87. Check and replace gears if necessary.
Loose gears.	Gear locknuts not torqued properly. Locking assembly not torqued properly. Worn gear key.	Torque gear nut to specified torque value. See page 87. Check and replace gears if necessary. Inspect gear key, shaft keyway and shaft, replace if necessary.
Loose bearings, axially or radially.	Lack of lubrication. Excessive hydraulic loads. Product or water contamination.	Check lubrication level and frequency. Reduce hydraulic loads. Replace bearings if necessary.
Damaged front oil seals.	Seal may be old and worn. No oil on lips to lubricate. Shaft worn under seals. Worn bearings.	Replace seals. Properly lubricate with oil when installing. Inspect shaft surface under seals. Replace bearings.
Damaged rear oil seal.	Seal may be old and worn. No oil on lips to lubricate. Shaft worn under seals. Not centered on shaft when installed. Worn bearings.	Replace seal. Properly lubricate with oil when installing. Inspect shaft surface under seals. Replace bearings.

Fluid Head Disassembly

⚠ DANGER

The pump contains internal moving parts. DO NOT put hands or fingers into the pump body ports or drive area at any time during operation. To avoid serious injury, DO NOT install, clean, service, or repair pump unless all power is off and locked out and the pump is de-pressurized.

⚠ DANGER

To avoid serious injury, shut off and drain product from the pump prior to disconnecting the piping.

⚠ WARNING

The pump components and piping may contain sharp edges. Handle the screws carefully because edges may be sharp. Wear gloves while installing and servicing the pump to help avoid injuries from these hazards.

Remove cover

1. Remove the cover nuts from the cover.



Figure 27 - Remove cover nuts



Figure 28 - Remove pump cover

2. Remove the cover from the body. If necessary, use a soft hammer to tap the cover off the body studs and dowel pins.



Figure 29 - Remove cover gasket

3. Remove and inspect the cover gasket.

NOTE: On the 220-UTS (not pictured), this gasket is installed in the groove on the body, not on the cover.

Remove screws

Figure 30 - Loosen screw nuts

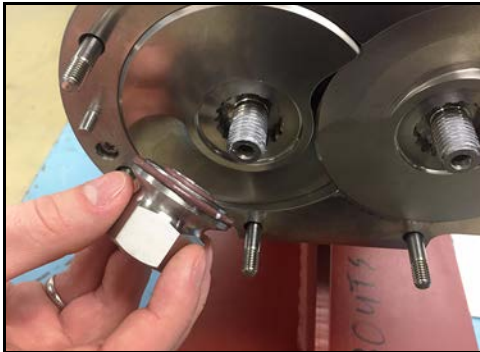

Figure 31 - Remove screw nuts



Figure 32 - Remove screw nut O-ring



Figure 33 - Remove washer retainer O-ring

1. Block the screws from turning using a food grade blocker (For the 015, 030, and 130-UTS, see "Screw Blocking Tool" on page 114), then loosen the screw nuts.

2. Remove the screw nuts.

3. Remove the screw nut O-ring from the outer O-ring groove on each screw nut.

4. Remove the washer retainer O-ring from the inner O-ring groove on each screw nut.



Figure 34 - Install belleville washer

5. Remove the belleville washers from the screw nuts. Inspect the washers and replace them if damaged.

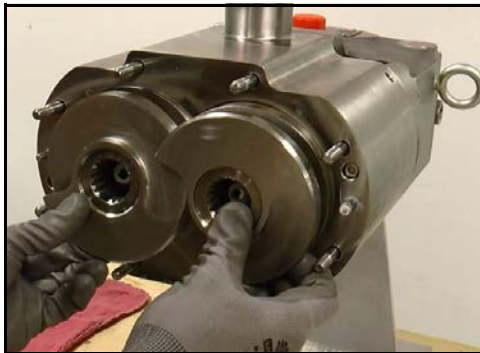

Figure 35 - Remove screws

6. Remove the screws simultaneously.

⚠ WARNING

The pump components and piping may contain sharp edges. Handle the screw screws carefully because edges may be sharp. Wear gloves while installing and servicing the pump to help avoid injuries from these hazards.



Figure 36 - Screws arranged LH - RH

7. Make note of which screw is the right-hand screw (marked RH), and which is the left-hand screw (marked LH), for later reassembly.

NOTE: *The markings are on the front of the screw in the recessed area around the shaft spline hole. The SPX FLOW part number is also marked here; the smaller/lower part number goes on the right-hand side.*

Remove seal cap and seal

1. Remove the seal cap assembly (seal cap and seal seat) from each shaft.



Figure 37 - Remove seal cap assembly



Figure 38 - Remove seal seat from seal cap

2. Remove the seal seat from the seal cap and place it on a clean, protected surface.



Figure 39 - Remove cap-to-screw O-ring

3. Remove the cap-to-screw O-ring from the smaller side (product side) of the seal cap.



Figure 40 - Remove cap-to-seat O-ring

4. Remove the cap-to-seat O-ring from the larger side (flush side) of the seal cap.

Removing seal without removing body

NOTE: Steps 1-4 below are shown without removing the pump body. These steps can also be performed after the pump body is removed. To remove the seal after removing the pump body, skip to "Remove pump body" on page 34.

1. Remove the seal from each shaft.

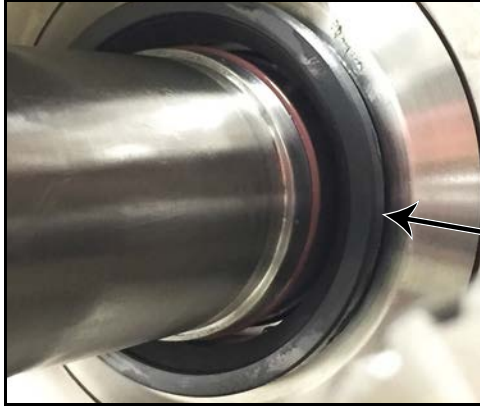

Figure 41 - Remove seal

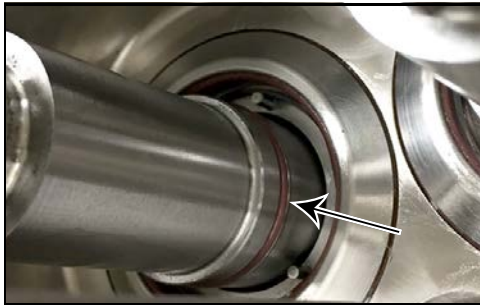

Figure 42 - Remove shaft O-ring

2. Remove the shaft O-ring from the O-ring groove on each shaft, as shown in Figure 42.



Figure 43 - Remove carrier-to-seal O-ring

3. Remove the carrier-to-seal O-ring from each shaft. If necessary, use the O-ring removal tool (part number on page 114) or an ice pick to aid in removing this O-ring.

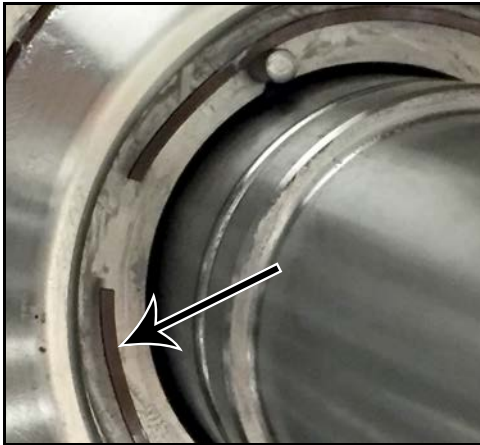

Figure 44 - Remove seal wave spring

4. Remove and inspect the seal wave spring on each shaft.

Remove pump body

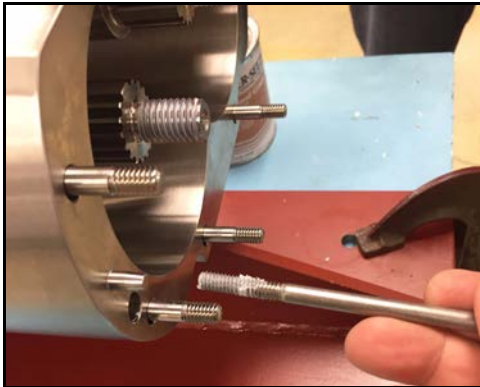

Figure 45 - Remove body retaining screws

1. Using an Allen wrench, remove the two body retaining screws. (The body retaining screws are located next to the small dowel pins on the body. See the diagram on page 96. The body retaining screws are item 11.)

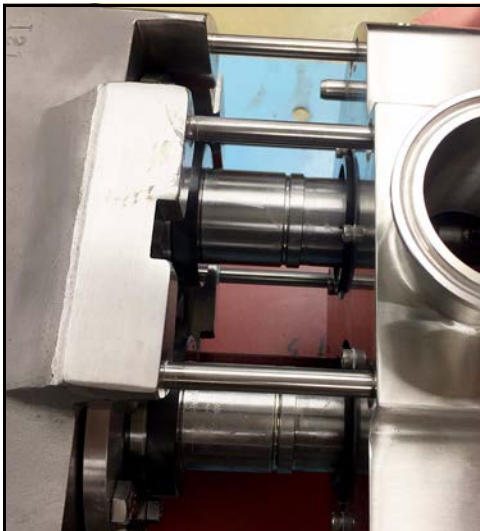

Figure 46 - Remove pump body

2. Remove the pump body and place it on a protected surface. When removing the pump body, be careful not to damage the seals with the shafts.

For a double seal, continue.

For a single seal, skip to step 1 on page 36.

Double seal - remove seals

1. (Double seal only) Remove the seal seats from the shafts by hand. Pull the seal seats toward the end of the shafts. The arrows in Figure 47 show the seal seat location.

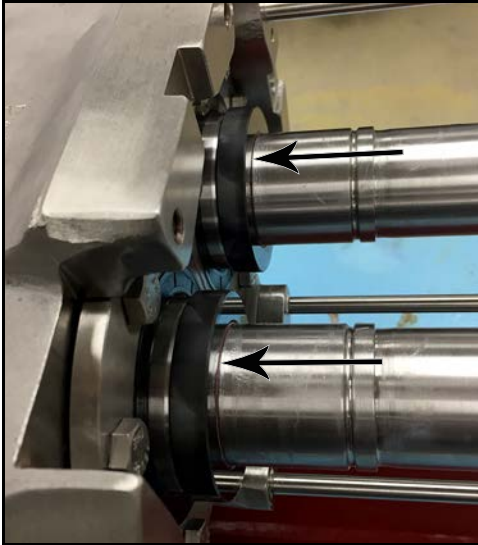

Figure 47 - Remove seal seats

2. (Double seal only) After removing the seal seat, remove the shaft O-rings from the O-ring groove closest to the gear case.

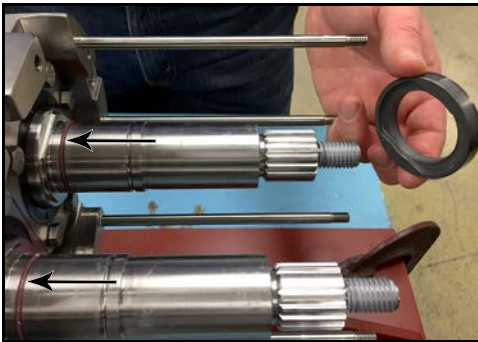

Figure 48 - Remove shaft O-rings

3. (Double seal only) Remove the seal from the seal carrier, and place it on a clean, protected surface.



Figure 49 - Remove seal

Single and double seal - remove seal carrier

1. Using an Allen wrench, remove the three cap screws holding the seal carrier to the body.

NOTE: It can be helpful to loosen the cap screws halfway and then lightly tap them with a hammer in order to help remove the seal carrier.



Figure 50 - Remove cap screws

2. Remove the seal carrier from the body.

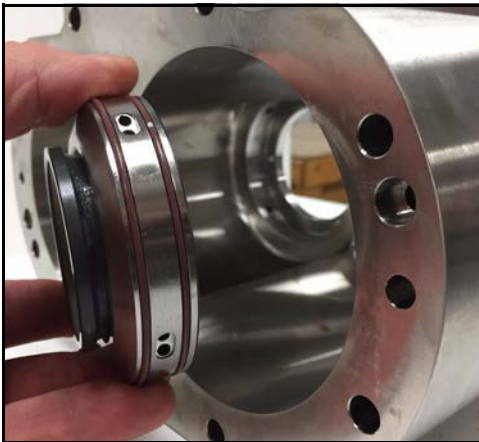

Figure 51 - Remove seal carrier from body

Removing seal after body is removed

1. Remove the seal from the product side of the seal carrier, and place it on a clean, protected surface.

NOTE: The product side of the seal carrier has an angle and has no mounting holes.

NOTE: This step can also be performed with the body installed. See "Removing seal without removing body" on page 33.



Figure 52 - Remove seal

2. Remove the carrier-to-seal O-ring from the product side of the seal carrier.

NOTE: This step can also be performed with the body installed. See "Removing seal without removing body" on page 33.



Figure 53 - Carrier-to-seal O-ring installed



Figure 54 - Seal wave spring

3. Remove the seal wave spring from the product side of the seal carrier.

For a single seal, skip to step 5.

For a double seal, continue.

NOTE: This step can also be performed with the body installed. See "Removing seal without removing body" on page 33.

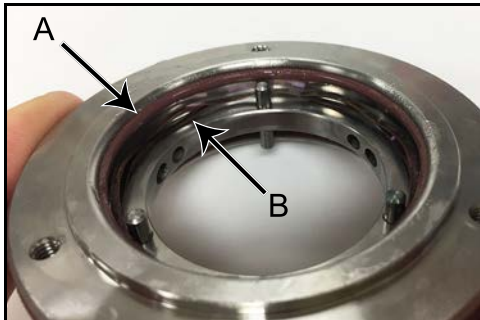

Figure 55 - O-ring and wave spring

4. For a double seal, remove the carrier-to-seal O-ring (A) and the seal wave spring (B) from the flush side of the seal carrier.



Figure 56 - Carrier-to-body O-rings

5. Remove the carrier-to-body O-rings from the two grooves on the outside of the seal carrier.

Fluid Head Assembly

⚠ WARNING

The pump components and piping may contain sharp edges. Handle the screws carefully because edges may be sharp. Wear gloves while installing and servicing the pump to help avoid injuries from these hazards.

Seal assembly

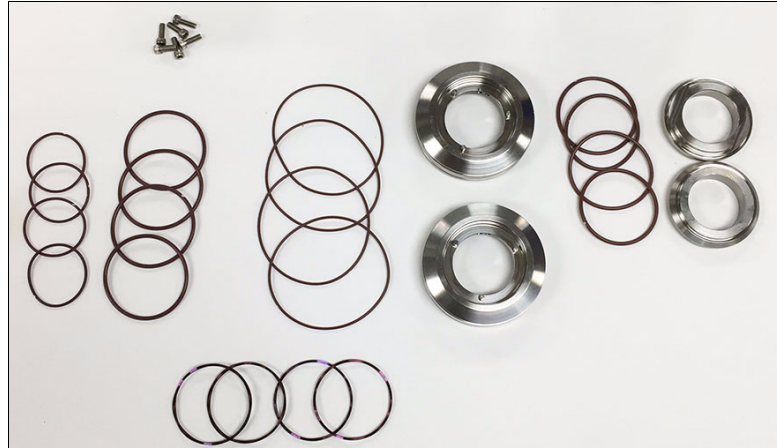

Figure 57 - Seal Assembly Components

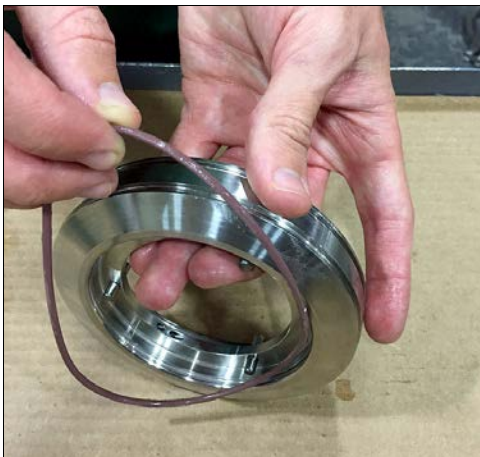

Figure 58 - Seal Carrier

1. Lubricate the carrier-to-body O-rings and install them onto the two grooves on the outside of the seal carrier.



Figure 59 - O-rings installed

2. Figure 59 shows the carrier-to-body O-rings installed on the seal carrier.

Installing seals before installing body

NOTE: Steps 1-4, 7, and 8 can be performed after installing the body; see "Installing seals after the body is installed" on page 46.

1. Install the seal wave spring into the product side of the seal carrier.

NOTE: The product side of the seal carrier has an angled surface and has no mounting holes.



Figure 60 - Seal wave spring



Figure 61 - Seal wave spring installed

2. Figure 61 shows the seal wave spring installed in the seal carrier.

NOTE: Make sure the wave spring is positioned on the outside of the pins.

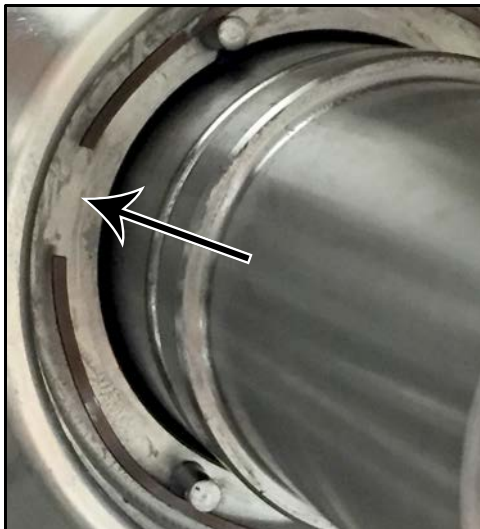

Figure 62 - Seal wave spring position

NOTE: On the 015-UTS and 220-UTS, the wave spring is a single layer. Make sure that the gap in the wave spring is positioned between the pins.



Figure 63 - Carrier-to-seal O-ring

3. Lubricate the carrier-to-seal O-ring and install it in the groove on the inside of the of the seal carrier. This O-ring groove is located on the product side of the seal carrier.

NOTE: The product side of the seal carrier has an angled surface and has no mounting holes.



Figure 64 - Carrier-to-seal O-ring installed

4. Figure 64 shows the carrier-to-seal O-ring installed in the product side of the seal carrier.

For a single seal, skip to step 7.

For a double-seal, continue.



Figure 65 - Seal wave spring installed

5. For a double-seal, flip the seal carrier over and install the second seal wave spring on the flush side of the seal carrier.

NOTE: On the 015-UTS and 220-UTS, the wave spring is a single layer. Make sure that the gap in the wave spring is positioned between the pins. See Figure 62 on page 39.



Figure 66 - Carrier-to-seal O-ring installed

6. (Double seal only) Lubricate and install the second carrier-to-seal O-ring in the flush side of the seal carrier.



Figure 67 - Lubricate and install seal

7. Lubricate the O.D. of the seal (see Figure 75 on page 42) and place it in the product side of the seal carrier. Align the slots in the seal with the pins in the seal carrier.



Figure 68 - Install seal

8. Make sure the slots in the seal align with the pins in the seal carrier, then press down evenly on all sides of the seal to install it in the seal carrier.
9. Repeat steps 1 to 8 for the seal carrier for the other shaft.

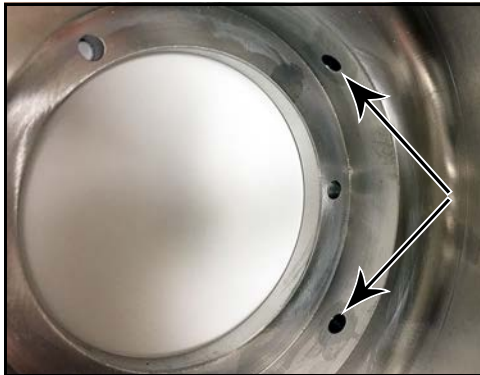

Figure 69 - View of flush holes on inside of pump body

10. The flush holes in the body are located toward the outside of the body (not toward the middle).

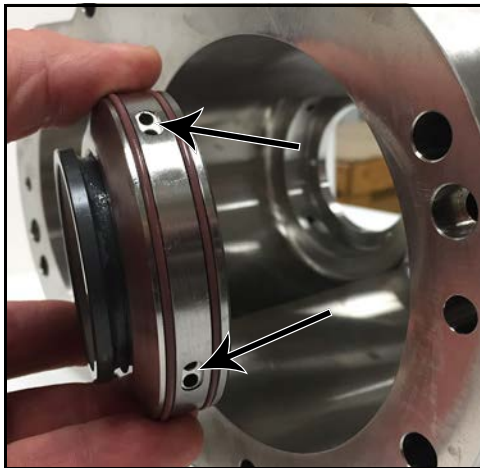

Figure 70 - Install seal carrier in body

11. Install the seal carrier into the body, making sure to line up the flush holes in the seal carrier with the flush holes in the body.

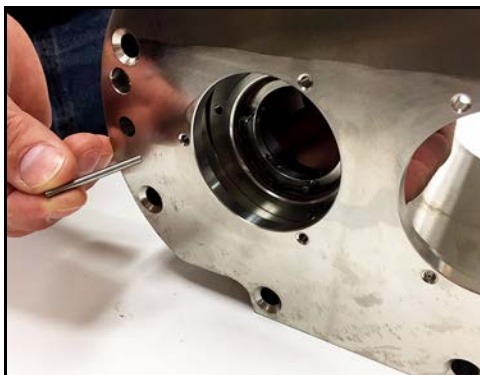

Figure 71 - Use drift pin to align holes

12. On the back side of the body, use an appropriately-sized drift pin to align the holes in the seal carrier with the holes in the body.

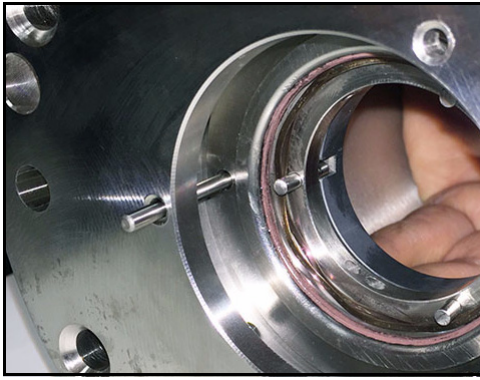

Figure 72 - Use drift pin to align holes



Figure 73 - Apply anti-seize



Figure 74 - Install with cap screws



Figure 75 - Lubricate the OD of the seal

13. Figure 72 shows the drift pin aligning the holes in the seal carrier with the holes in the body. (Double seal shown.) Once aligned, remove the drift pin.

14. Apply anti-seize to the six socket head cap screws.

15. Using an Allen wrench, install the seal carrier into the body with 3 cap screws. Snug down the cap screws by hand, taking care not to over-tighten. (Double seal shown.)

16. Repeat to install the second seal carrier in the body.

For a single seal, skip to step 5 on page 44.

For a double seal, continue.

17. (Double seal only) Lubricate the OD of the seal to ease assembly. This seal is installed in the flush side of the seal carrier, from the back side of the body.



Figure 76 - Install seal

18. (Double seal only) Align the drive slots in the seal with the pins on the seal carrier, then press the seal into the carrier.

NOTE: This may require a hard push, but use caution not to break the seal.

19. (Double seal only) Repeat steps 17 and 18 to install the seal in the second seal carrier.

Install body

For a single seal, skip to step 5 on page 44.

For a double seal, continue.

1. (Double seal only) Lubricate two shaft O-rings.



Figure 77 - Lubricate O-rings

2. (Double seal only) Install one O-ring on each shaft in the O-ring groove closest to the gear case, as shown in Figure 78.



Figure 78 - Install shaft O-rings

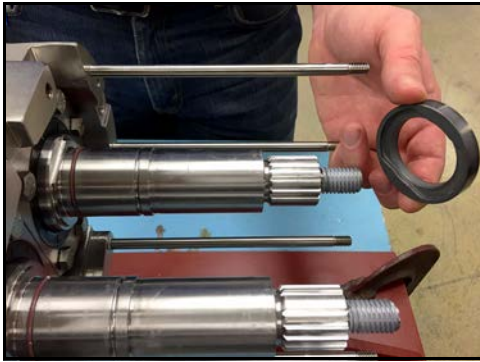

Figure 79 - Install seal seats

3. (Double seal only) Line up the flats on the inside seal seat with the flats on the shaft, and slide the seal seats over the O-ring, until they are seated against the base of the shaft.

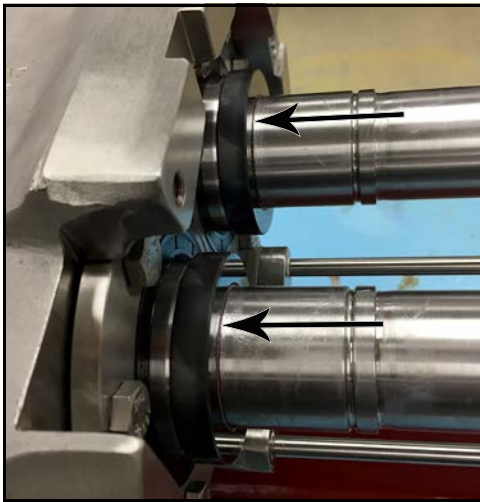

Figure 80 - Seal seats installed

4. (Double seal only) Make sure the seal seat is seated against the flats on the shaft, locking the seal seat against the base of the shaft. The arrows in Figure 80 show the seal seat location.



Figure 81 - Install pump body onto shafts

NOTE: These steps apply to both the single and double seal. Double seal is shown.

5. Use the studs to help center the pump body. Slide the pump body all the way on until it is seated against the gear case.

NOTE: Be very careful not to damage the seals while installing the pump body on the shafts.

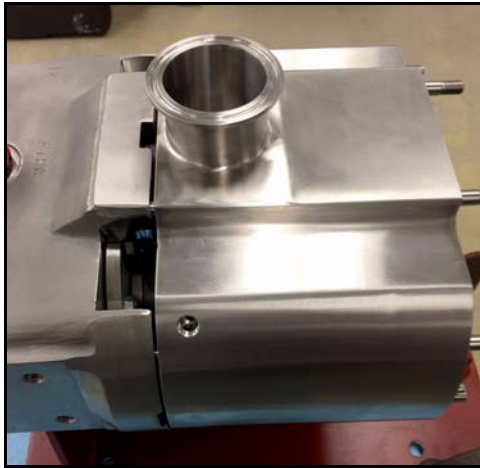

Figure 82 - Pump body installed

6. Pump body installed, shown in Figure 82.



Figure 83 - Apply anti-seize to threads

7. Apply anti-seize to the threads of the body retaining screws.

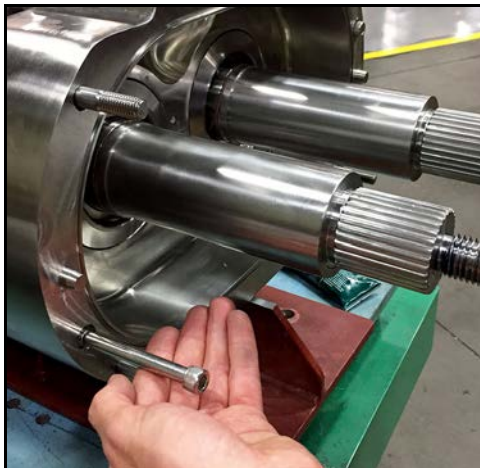

Figure 84 - Install body retaining screws

8. Using an Allen wrench, install the two body retaining screws in the holes next to the dowel pins, and hand-tighten. (220-UTS shown.)

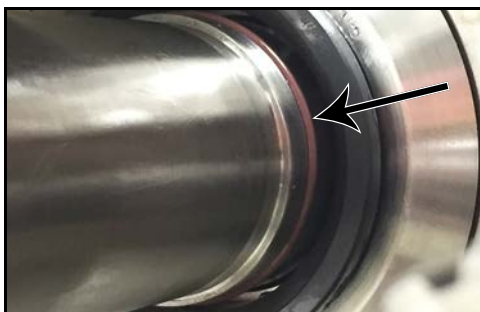

Figure 85 - Install shaft O-ring

9. If the seal has already been installed, lubricate the shaft O-ring, then slide the shaft O-ring over the shoulder in the shaft, and install it into the O-ring groove. See Figure 85. Repeat for the second shaft, then skip to “Seal cap assembly” on page 47.

Installing seals after the body is installed

1. Install the seal wave spring on each shaft.

NOTE: On the 015-UTS and 220-UTS, the wave spring is a single layer. Make sure that the gap in the wave spring is positioned between the pins as shown in Figure 86.

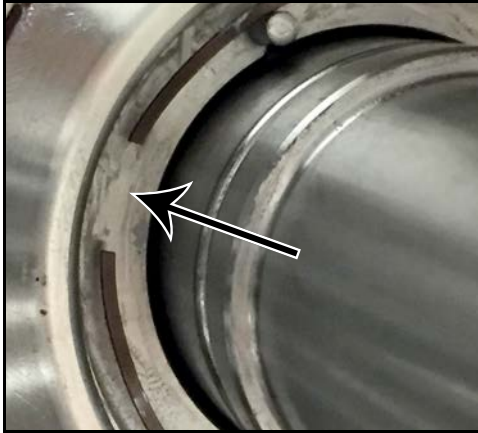

Figure 86 - Seal wave spring position

2. Lubricate the carrier-to-seal O-ring and install it in the groove on the inside of the seal carrier.

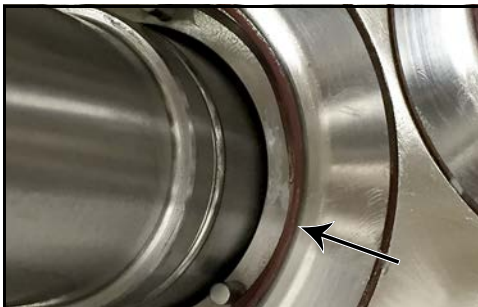

Figure 87 - Install carrier-to-seal O-ring

3. Lubricate the shaft O-ring. Slide the shaft O-ring over the shoulder in the shaft, and install it into the O-ring groove, as shown in Figure 88. Repeat for the second shaft.

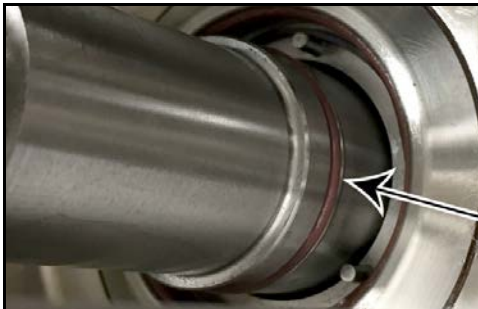

Figure 88 - Install shaft O-ring

4. Align the drive slots in the seal with the pins on the seal carrier, then press the seal into the seal carrier.

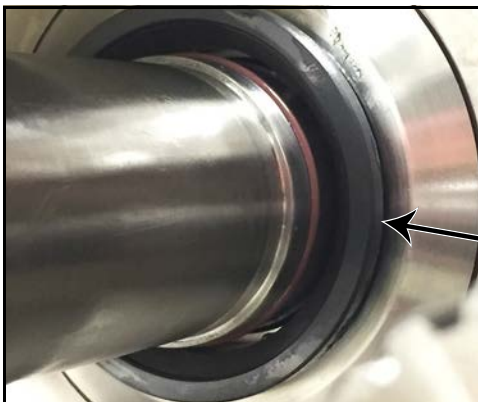

Figure 89 - Install seal

Seal cap assembly

Applies to both single and double seals.



Figure 90 - Seal Cap Assembly Components



Figure 91 - Install cap-to-seat O-ring



Figure 92 - Cap-to-seat O-ring installed



Figure 93 - Install cap-to-screw O-ring

1. Place the seal cap on a protected surface, making sure the side with the milled flats is facing up. Lubricate the cap-to-seat O-ring and install it on the seal cap. Repeat for the second seal cap.
2. Figure 92 shows the cap-to-seat O-ring installed on the seal cap.
3. Lubricate and install the cap-to-screw O-ring on the opposite side of the seal cap (the side without the milled flats). Repeat for the second seal cap.



Figure 94 - Cap-to-screw O-ring installed



Figure 95 - Line up seal cap and seal seat



Figure 96 - Seal seat installed on seal cap



Figure 97 - Install seal cap assembly



Figure 98 - Seal cap installed on shaft

4. Figure 94 shows the cap-to-screw O-ring installed on the seal cap.
5. Line up the flats on the seal cap, with the flats on the seal seat, and place the seal seat on the seal cap.
6. Figure 96 shows the seal seat installed on the seal cap.
7. Install the seal cap assembly on the shaft. Make sure the face of the seal seat is seated against the face of the seal previously installed on the shaft.
8. Figure 98 shows the seal cap assembly installed on the shaft. See the note next to Figure 99 on page 49.

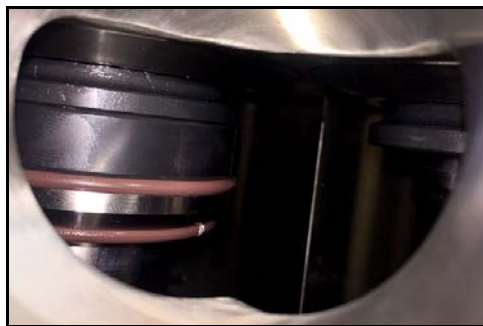

Figure 99 - View through port

NOTE: If the port is not connected to piping, look through it to visually confirm that all the O-rings and seal faces are installed correctly.

Install screws

⚠ WARNING

The pump components and piping may contain sharp edges. Handle the screws carefully because edges may be sharp. Wear gloves while installing and servicing the pump to help avoid injuries from these hazards.



Figure 100 - Apply anti-seize

1. Apply anti-seize to the inner rim of the screw to ease assembly.



Figure 101 - Arrange screws: LH-RH

2. Looking at the front of the pump, arrange the screws so the screw marked LH is on the left side, and the screw marked RH is on the right side.

NOTE: The markings are on the front of the screw in the recessed area around the shaft spline hole. The SPX FLOW part number is also marked here; the smaller/lower part number goes on the right-hand side.



Figure 102 - Align screw and shaft spline

3. Look at the position of the indexing tooth on each shaft spline and roughly align the screw splines to match.

For 220-UTS, skip to step 6 on page 50.

For all other sizes, continue.



Figure 103 - Install screws

4. (All sizes except 220-UTS) Making sure each screw spline roughly matches the indexing tooth of each shaft spline (see arrows in Figure 102 on page 49), slide the screws onto the shafts as a pair.
5. (All sizes except 220-UTS) Once the beginning of the shaft spline meets the screw spline, make sure that the indexing teeth are lined up exactly. Lift up slightly on the screws, then push on the screws so that the splines engage. Push the screws onto the shafts completely, until they are flush with the edge of the seal caps.

⚠ WARNING

Pinch point: Be careful not to pinch your fingers between the screws and the pump body.

⚠ WARNING

The pump components and piping may contain sharp edges. Handle the screw screws carefully because edges may be sharp. Wear gloves while installing and servicing the pump to help avoid injuries from these hazards.

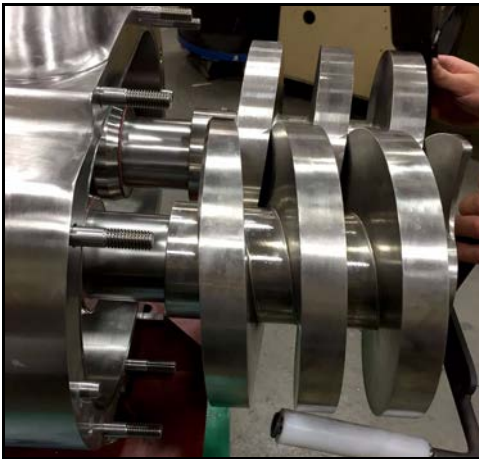

Figure 104 - Slide screws onto shafts

6. (220-UTS) Roughly line up the indexing teeth of the screw and shaft splines, then slide the screws onto the shafts as a pair. The screws will go on about halfway and then stop. At this point you can let the screws rest on the shafts.
7. (220-UTS) Lift up slightly on the screws, then slide them on, up to the splines. Make sure the indexing teeth are lined up exactly, then lift up slightly on the screws and push them on completely, until the screws are flush with the edge of the seal caps.

⚠ WARNING

Pinch point: Be careful not to pinch your fingers between the screws and the pump body.

⚠ WARNING

The pump components and piping may contain sharp edges. Handle the screw screws carefully because edges may be sharp. Wear gloves while installing and servicing the pump to help avoid injuries from these hazards.

8. Figure 105 shows the screws installed in the pump (030-UTS pictured).

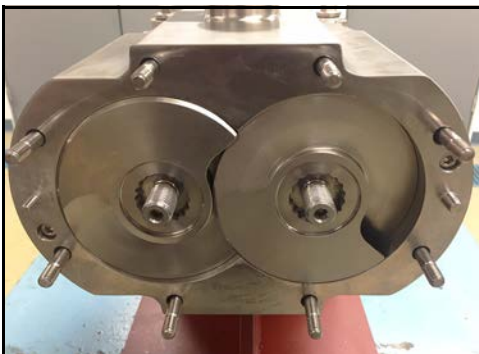

Figure 105 - Screws installed

Screw nut assembly**Figure 106 - Screw Nut Components****Figure 107 - Install belleville washer****Figure 108 - Install washer retainer O-ring****Figure 109 - Belleville washer installed**

1. Assemble the screw nuts: Place the belleville washer onto the screw nut. The belleville washer must be installed so the outer edge of the washer raises up over the edge of the screw nut.
2. Install the washer retainer O-ring onto the inner O-ring groove on the screw nut.
3. Figure 109 shows the washer retainer O-ring and belleville washer correctly installed. If the edge of the washer is lower than the edge of the nut, flip the washer over.



Figure 110 - Install screw nut O-ring



Figure 111 - Screw nut assembly



Figure 112 - Apply anti-seize



Figure 113 - Install screw nuts

4. Install the screw nut O-ring onto the outer O-ring groove on the screw nut. Lubricate the O-ring.

5. Figure 111 shows the Belleville washer and O-rings correctly installed.

6. Apply anti-seize to the threads on the shafts.

7. Install the screw nuts on the pump shafts and hand-tighten.



Figure 114 - Torque left screw

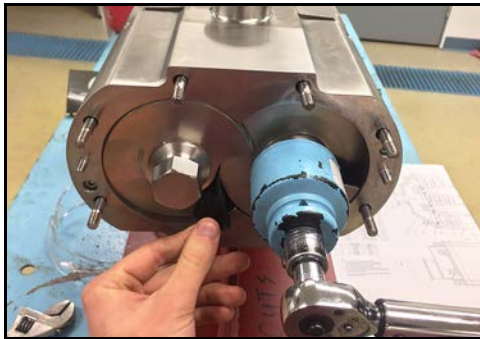

Figure 115 - Torque right screw

8. Block the screws from turning using a blocking dowel (for 015, 030, and 130-UTS, see "Screw Blocking Tool" on page 114). Torque the left screw nut to specification (see Table 4, below).

015-UTS	12 ft-lb (16 N·m)
030-UTS	38 ft-lb (52 N·m)
130-UTS	88 ft-lb (119 N·m)
220-UTS	200 ft-lb (271 N·m)

9. For the 015, 030, 130-UTS: Block between the screws as shown in Figure 115 (see "Screw Blocking Tool" on page 114).

For the 220-UTS (not shown), block the back of the threads using a food-grade blocker compatible with the product.

10. Torque the right screw to the specification in Table 4.
11. Remove the screw blocker and spin the pump over to confirm it rotates freely. If the pump does not spin over freely, fix the interference before starting the pump.

NOTE: To time the screws, see "Install Gears and Time Screws" on page 75.

Install cover

1. Install the cover gasket, flat side facing up, into the groove in the cover. (On the 220-UTS (not pictured), this gasket is installed in the groove on the body, not on the cover.)

NOTE: It may be helpful to lubricate the cover gasket to help hold the gasket in place in the groove.

NOTE: For the 220-UTS, it may also be helpful to place four dots of lubricant at four spots in the groove, to help hold the gasket in place.



Figure 116 - Install cover gasket



Figure 117 - Install pump cover

2. All sizes *except* 220-UTS: Align the cover holes with the lower cover studs, then slide the cover onto the pump.

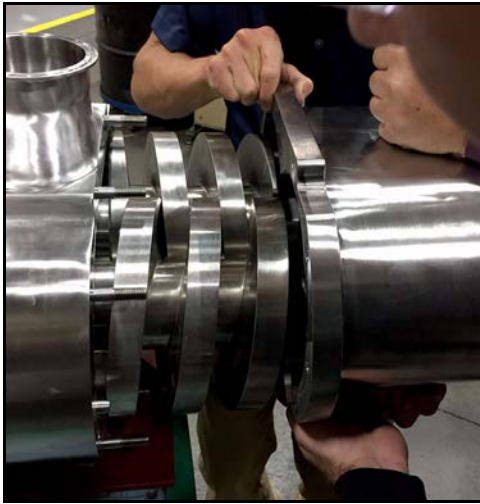

Figure 118 - 220-UTS Install pump cover

3. 220-UTS only: Align the screw case alignment dowels with the holes in the cover, and slide the pump cover over the screws onto the pump.



Figure 119 - Seat pump cover against pump body

4. Seat the pump cover against the pump body (220-UTS pictured).



Figure 120 - Apply anti-seize to threads

5. Apply anti-seize to the threads of the cover studs.



Figure 121 - Torque cover nuts

6. Torque the cover nuts to the specified torque (see below).

Table 5: Torque Values - Cover Nut	
015-UTS	7 ft-lb (10 N·m)
030-UTS	11 ft-lb (15 N·m)
130-UTS	25 ft-lb (34 N·m)
220-UTS	55 ft-lb (75 N·m)

Gear Case Disassembly

⚠ DANGER

To avoid serious injury, DO NOT install, clean, service, or repair the pump unless all power is off and locked out and the pump is de-pressurized.

⚠ DANGER

To avoid serious injury, shut off and drain product from the pump prior to disconnecting piping.

Remove oil drain plugs and cover

1. Remove one of the oil drain plugs (location shown in Figure 122, item 45) and drain the oil.

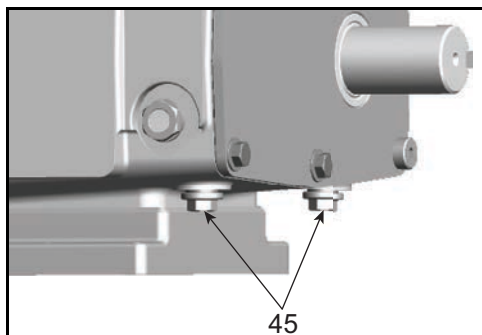

Figure 122 - Remove oil drain plug

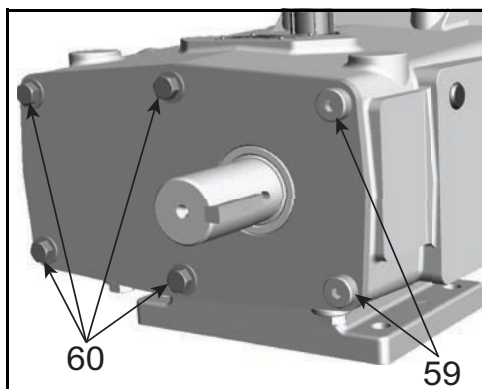

Figure 123 - Remove fasteners

2. Remove the fasteners from the gear case cover; the two socket head shoulder bolts (Figure 123, item 59) from the two holes by the drive shaft, and the four (six on the 220-UTS) hex head cap screws (item 60) from the remaining holes.



Figure 124 - Remove gear case cover

3. Remove the gear case cover. Discard the cover gasket.

Remove gear from short shaft

1. Block the shafts from turning.



Figure 125 - Block shafts

2. With an Allen wrench, loosen the screws in the locking assembly by quarter turns, until you can see a few threads.



Figure 126 - Loosen bolts in locking assembly

3. If the locking assembly does not self-release, tap the screws lightly with a mallet (or use thread jacking holes) to loosen the gear.

NOTE: Wrap the liquid end shafts with tape to prevent damage to the threads.



Figure 127 - Locking assembly

4. Pull the gear and locking assembly off the shaft and place it on a protected surface.

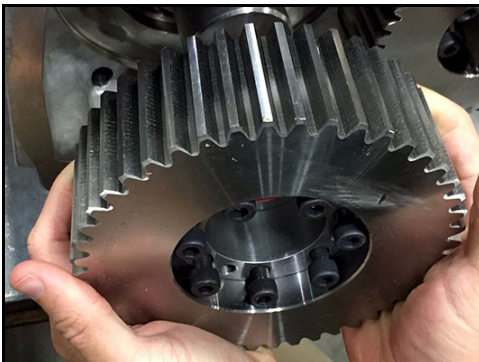

Figure 128 - Remove gear

Remove gear from drive shaft

1. Align the tabs on the socket of the gear nut driver tool (part numbers on page 112) with the indents on the locking nut.

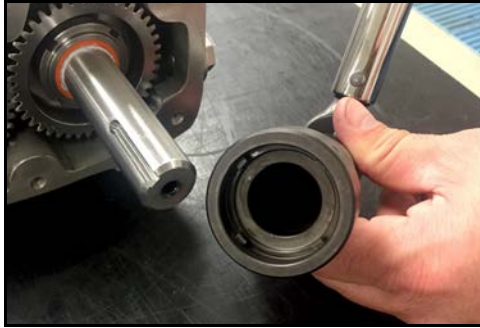

Figure 129 - Remove locking nut

2. Loosen the locking nut.



Figure 130 - Loosen locking nut

3. Remove the locking nut.



Figure 131 - Remove locking nut and gear

Remove shaft

1. Loosen and remove the bearing retainer screws.

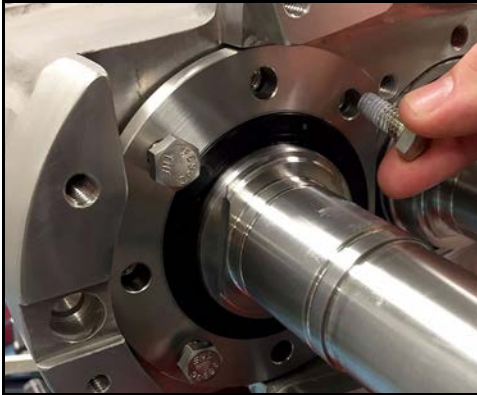

Figure 132 - Loosen and remove bearing retainer screws

2. Remove the bearing retainers.



Figure 133 - Remove bearing retainer

3. Grasp the shaft with one hand and tap it out of the gear case with a rubber mallet as shown in Figure 134.

NOTE: A hydraulic press may be required to remove the shafts.

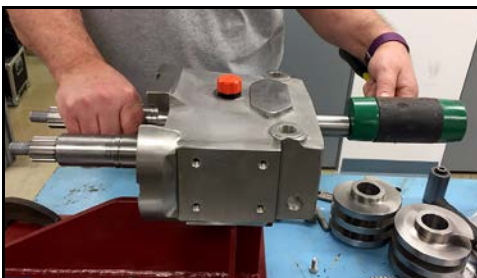

Figure 134 - Tap drive shaft out of gear case

4. Pull the drive shaft out of the gear case. Remove the drive gear.



Figure 135 - Pull drive shaft out of gear case

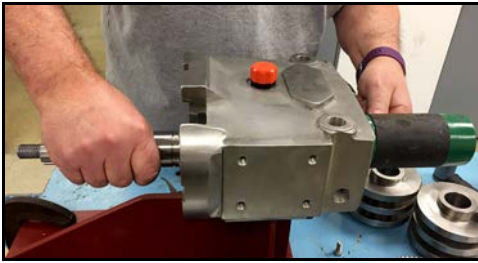

Figure 136 - Tap short shaft out of gear case

5. With a rubber mallet, tap the short shaft out of the gear case.

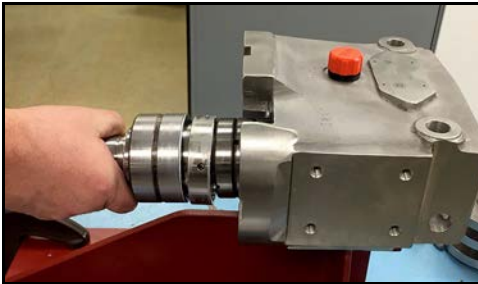

Figure 137 - Pull short shaft out of gear case

6. Pull the short shaft out of the gear case.

Shaft disassembly

1. Before pressing, remove the outer race of the needle roller bearing.
2. Use a hydraulic press and V-blocks Figure 138, item A) to remove the bearings (items 1 and 2) and gear spacer (on drive shaft only, not shown).

NOTE: Make sure both ends of the shaft are protected when removing the shaft.

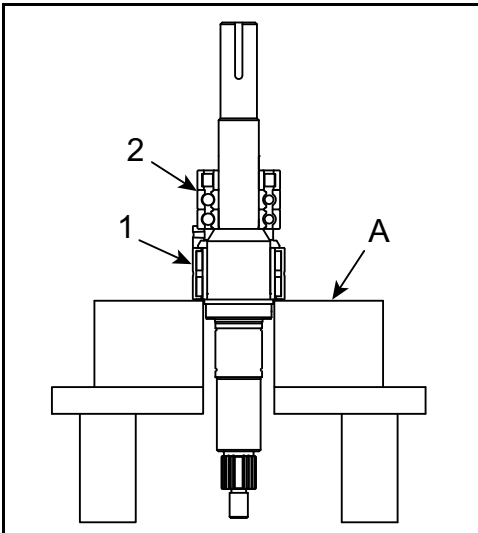

Figure 138 - Press bearings off shaft

Gear Case Assembly

⚠ DANGER

To avoid serious injury, DO NOT install, clean, service, or repair the pump unless all power is off and locked out, and the pump is de-pressurized.

⚠ DANGER

To avoid serious injury, shut off and drain product from the pump prior to disconnecting piping.

Shaft assembly

Table 6: Shaft assy. components

Items needed, top, L-R in Figure 139 and Figure 140):

Needle roller bearing

Bearing spacer

Four point angular contact bearing

(x 2 per shaft, shown with plastic insert)

Cylindrical roller bearing

Figure 139, far right: Gear spacer

Figure 140, far right: Locking nut



Figure 139 - Drive Shaft: Assembly items needed



Figure 140 - Short Shaft: Assembly items needed



Figure 141 - Apply anti-seize

1. Apply a light coat of anti-seize to the circumference of the shaft as shown in Figure 141.

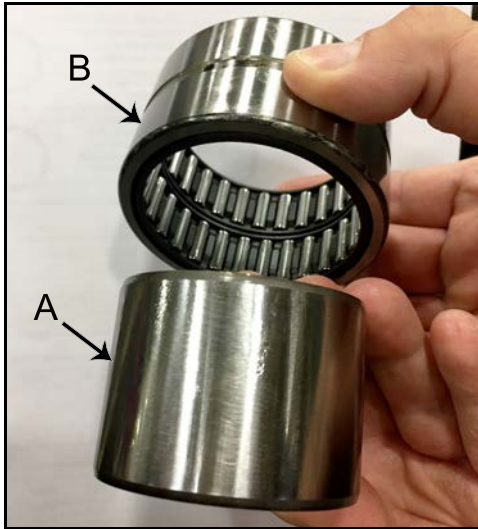

Figure 142 - Remove outer race of needle roller bearing

2. Remove the outer race (Figure 142, item B) of the needle roller bearing. (The inner race is item A.)

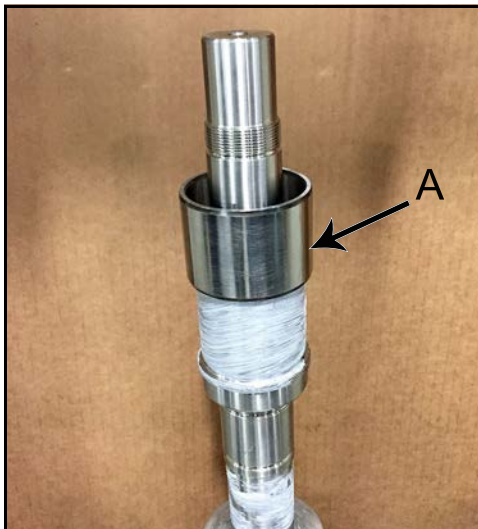

Figure 143 - Place inner race on shaft

3. Place the inner race of the needle roller bearing (Figure 143, item A) onto the shaft.

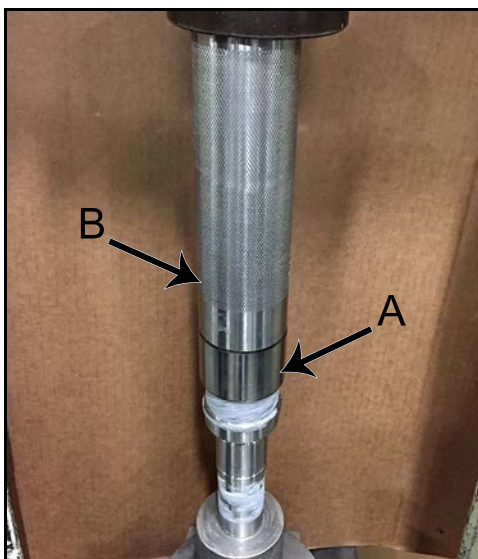

Figure 144 - Press race onto shaft

4. Press the inner race of the needle roller bearing (Figure 144, item A) onto the shaft as shown. Figure 144, item B is a bearing press assembly tool.

NOTE: The outer race of the needle roller bearing is installed later on page 71.



Figure 145 - Inner race installed on shaft

5. Press the inner race of the needle roller bearing onto the shaft until it seats against the lip of the shaft.



Figure 146 - Place bearing spacer on shaft

6. Place the bearing spacer onto the shaft as shown in Figure 146.

NOTE: Make sure the angled side (see arrow) of the bearing spacer is facing down toward the needle roller bearing.



Figure 147 - Bearing spacer installed

7. Figure 147 shows the bearing spacer in place on the shaft.

NOTE: Make sure the flat side of the bearing spacer is facing up.

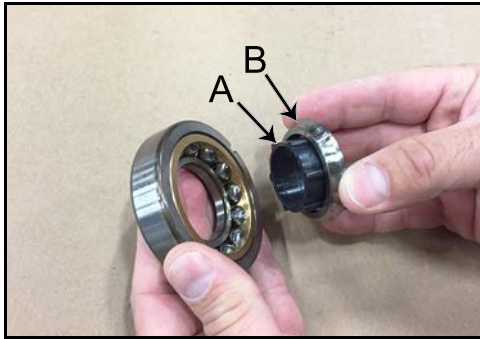

Figure 148 - Remove insert and race

8. Remove the plastic insert (Figure 148, item A) and race (B) from one of the two four point angular contact bearings.

NOTE: There are two four point angular contact bearings per shaft, and two races per bearing. The races are installed on the shaft individually, so for ease of identification during assembly, keep the races paired with the bearings. When you remove the races, face them toward the side of the bearing from which they have been removed.



Figure 149 - Remove bottom race

9. Remove the race from the other side of the four point angular contact bearing.

NOTE: There are two four point angular contact bearings, so make sure the races remain in position in relation to each bearing. The smaller side of each race always faces in toward the ball bearings; the larger flanged side of each race always faces out.



Figure 150 - Apply anti-seize to shaft

10. Apply a light coat of anti-seize to the shaft.



Figure 151 - Place race onto shaft

11. Place one race from the four point angular contact bearing onto the shaft. Note the position of the race. Make sure the flange faces down toward the shaft as shown in Figure 151.



Figure 152 - Press race onto shaft



Figure 153 - Race pressed on shaft



Figure 154 - Place bearing onto race

12. Press the race of the four point angular contact bearing onto the shaft. Make sure it seats against the step on the shaft as shown in Figure 152.

13. Figure 152 shows the race seated against the step on the shaft.

14. With the slot on the bearing facing down, place the four point angular contact bearing onto the race.

NOTE: The slot location does not affect the function.



Figure 155 - Place race on shaft



Figure 156 - Race installed on shaft



Figure 157 - Place race on shaft



Figure 158 - Press race into bearing

15. Place the second race of the four point angular contact bearing onto the shaft. Note the position of the race. Make sure the narrower side of the race faces down toward the ball bearings, as shown in Figure 155.

16. Press the race into the bearing.

17. Figure 156 shows the four point angular contact bearing installed on the shaft.

18. Place the race of the next four point angular contact bearing onto the shaft. Note the position of the race. Make sure the flanged side of the race faces down toward the shaft, as shown in Figure 157.

19. Press the race of the next four point angular contact bearing onto the shaft, until it seats against the angular contact bearing installed in step 17.



Figure 159 - Place bearing onto race



Figure 160 - Place race on shaft



Figure 161 - Press race into bearing



Figure 162 - Second bearing installed

20. Place the four point angular contact bearing onto the race.

21. Place the second race of the four point angular contact bearing onto the shaft. Note the position of the race. Make sure the narrower side of the race faces down toward the ball bearings as shown in Figure 160.

22. Press the race of the four point angular contact bearing onto the shaft, until it seats into the bearing.

23. Figure 162 shows the second four point angular contact bearing installed.

24. Apply anti-seize to the shaft.



Figure 163 - Remove race from bearing

25. Remove the inner race of the cylindrical roller bearing.



Figure 164 - Place race onto shaft

26. Place the inner race of the cylindrical roller bearing onto the shaft.



Figure 165 - Press race onto shaft

27. Press the inner race of the cylindrical roller bearing onto the shaft until it contacts the four point angular contact bearing already installed.



Figure 166 - Place bearing onto race

28. Place the outer race of the cylindrical roller bearing onto the inner race installed on the shaft.

29. For the drive shaft, repeat steps 1 through 28, then skip to step 33. For the short shaft, continue.



Figure 167 - Place locking nut onto shaft

- 30. Short shaft only: Apply anti-seize to the shaft.
Place the locking nut onto the shaft, and screw it on finger-tight.



Figure 168 - Torque down locking nut

- 31. Short shaft only: Place the shaft in a holding device clamped into a vise, then torque down the locking nut onto the shaft.

Table 7: Torque Values - Locking Nut	
015-UTS	15 ft-lb (20 N·m)
030-UTS	30 ft-lb (41 N·m)
130-UTS	45 ft-lb (61 N·m)
220-UTS	75 ft-lb (102 N·m)

- 32. Short shaft only: skip to “Install shafts in gear case” on page 70.

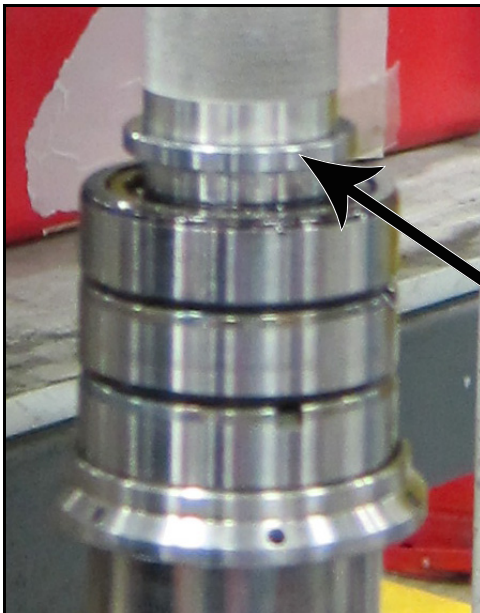

Figure 169 - Press gear spacer on drive shaft

- 33. Drive shaft only: Press the gear spacer onto the shaft until it contacts the cylindrical roller bearing already installed.

NOTE: Make sure the gear spacer is positioned so that the flanged side is up.



Figure 170 - Place key in keyway

34. Drive shaft only: Place the key in the keyway on the shaft.



Figure 171 - Tap key into keyway

35. Drive shaft only: Tap the key in with a hammer.

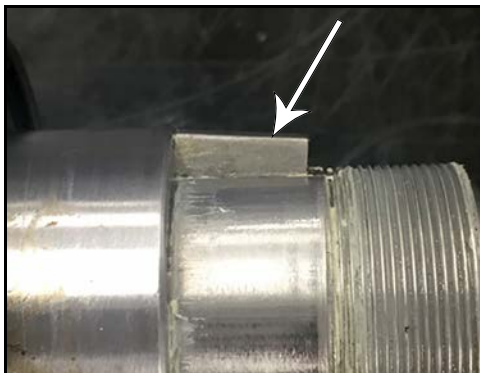

Figure 172 - Position key

36. Drive shaft only: Position the key so that it is angled down slightly toward the end of the shaft (toward the threads). This aids in installing the gear over the key.

Install shafts in gear case

1. Place the gear case on an arbor press. Apply anti-seize to the lip of the shaft bores.



Figure 173 - Apply anti-seize



Figure 174 - Spread even layer

2. Rub a finger around the bore to spread the anti-seize in a thin, even layer around the inner lip of the bore.



Figure 175 - Place short shaft in bore

3. Place the short shaft into the shaft bore, right-hand side as shown in Figure 175.

NOTE: In Figure 175, the gear case is positioned on end; the bottom of the gear case (with 4 holes for the mounting foot), facing toward the camera. The top of the gear case (the side with the nameplate and hole for the oil breather plug) is facing away from the camera.

NOTE: The UTS pump can only be mounted in one direction, so the shafts must be installed in the respective shaft bores as shown in Figure 175 and Figure 176.

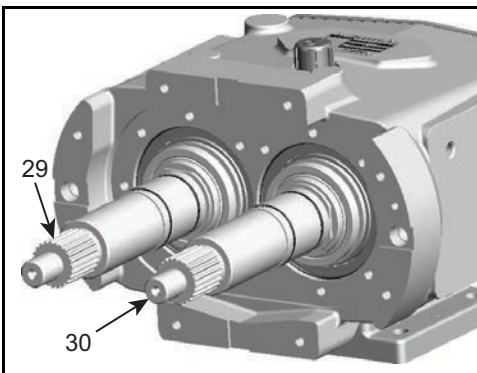

Figure 176 - Drive shaft (29) left-hand side, Short shaft (30) right-hand side

4. Figure 176 shows the gear case with shafts and mounting foot installed. In this view, the drive shaft (29) is on the left and the short shaft (30) is on the right.

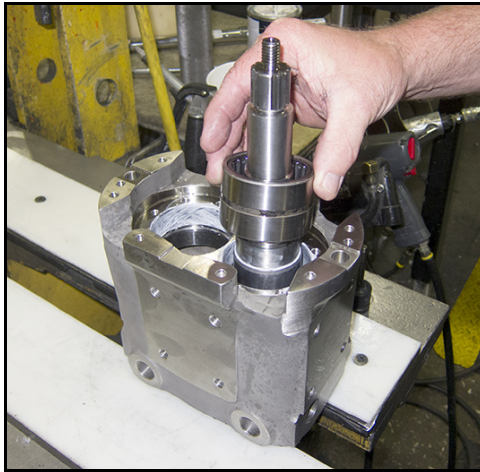

Figure 177 - Place outer race on shaft

5. Place the outer race of the needle roller bearing on the short shaft.

NOTE: The inner race of the needle roller bearing was pressed onto the shaft in step 3 on page 61.



Figure 178 - Place drive shaft in bore

6. Place the drive shaft in the left-hand bore as shown in Figure 178.

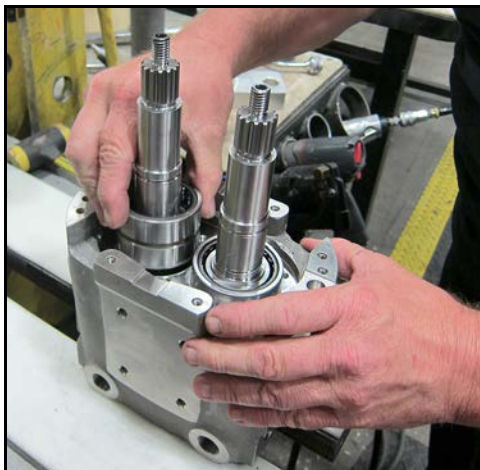

Figure 179 - Place outer race on shaft

7. Place the outer race of the needle roller bearing on the drive shaft.

NOTE: The inner race of the needle roller bearing was pressed onto the shaft in step 3 on page 61.



Figure 180 - Tap shafts to center in bores

8. Tap the shafts with a hammer to center them in the bores.



Figure 181 - Shafts seated in gearcase

9. Using a press, press on the outer race of each needle roller bearing until the outer bearing race seats in the gear case as shown in Figure 181.

Install Bearing Retainers

1. Center the bearing retainer seal on the bearing retainer with the flat side of the seal facing up, as shown in Figure 182.



Figure 182 - Center bearing retainer seal

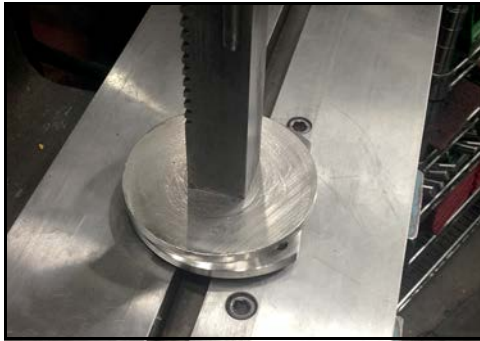

Figure 183 - Install bearing retainer seal

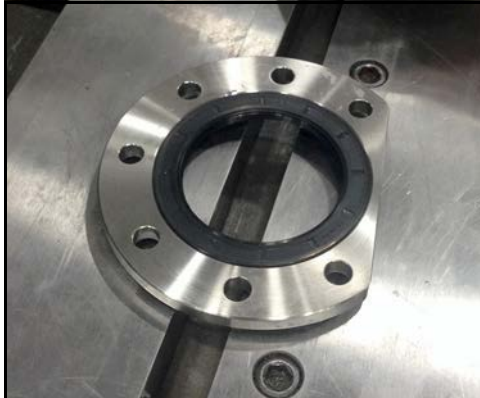

Figure 184 - Bearing retainer seal installed

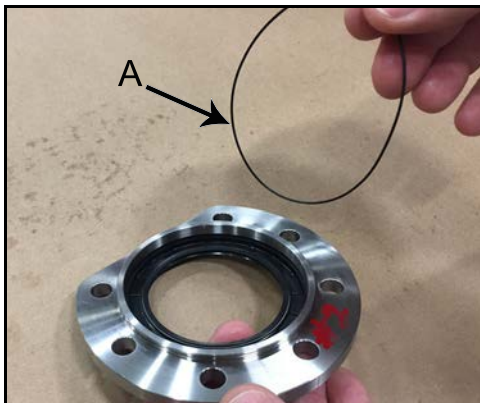

Figure 185 - Install bearing retainer O-ring

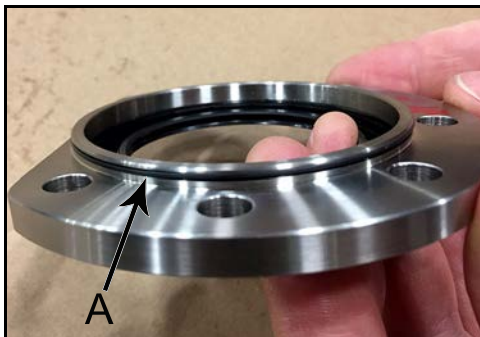

Figure 186 - Bearing retainer O-ring installed

2. Press to install the bearing retainer seal into the bearing retainer.
3. When correctly installed, the flat portion of the seal should be flush with the bearing retainer.
4. Repeat for the second bearing retainer.
5. Assemble the bearing retainer O-ring (item A) on the bearing retainer.
6. Figure 186 shows the bearing retainer O-ring (A) installed on the bearing retainer.
7. Repeat for the second bearing retainer.

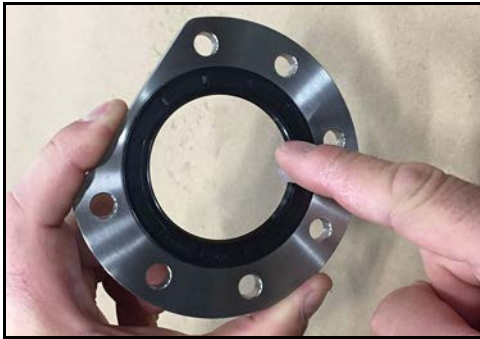

Figure 187 - Apply lubricant



Figure 188 - Install bearing retainer



Figure 189 - Install screws

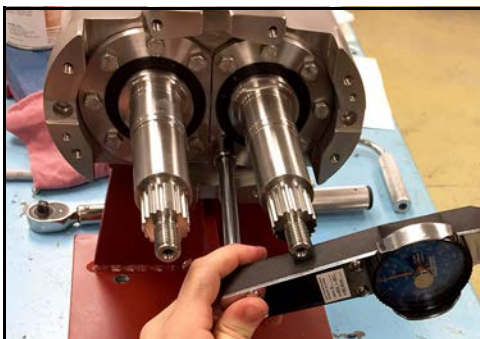

Figure 190 - Torque bearing retainer screws

8. Apply lubricant between the lips of the bearing retainer seal.

9. Install the bearing retainer on the shaft. Make sure the flat side of the bearing retainer faces the middle of the pump as shown in Figure 188.

10. Push one edge of the bearing retainer down, leaving the other side up, then apply pressure while slipping the other edge of the lip seal over the shaft.

NOTE: check to make sure that the lip seal did not roll during the installation.

11. Repeat for the second bearing retainer on the other shaft.

12. Apply anti-seize to the screws and install them in the bearing retainer as shown in Figure 189. Lightly snug down the screws by hand.

13. In an alternating pattern, torque the bearing retainer screws by hand to the specified torque listed below.

Table 8: Torque Values - Bearing Retainer Screws	
015-UTS	24 in-lb (2 ft-lb) 3 N·m
030-UTS	84 in-lb (7 ft-lb) 9 N·m
130-UTS	180 in-lb (15 ft-lb) 20 N·m
220-UTS	300 in-lb (25 ft-lb) 34 N·m

Install Gears and Time Screws

Tools Required:

- Shim pack/Feeler gauge
- Allen socket
- Socket extension
- Torque wrench
- Marker

Install gear on drive shaft

1. Install anti-seize on the threads of the shaft. Line up the notch in the drive gear with the key on the drive shaft. Make sure the flat side of the gear faces the gear case.



Figure 191 - Install drive gear



Figure 192 - Install drive gear

2. Install the drive gear on the drive shaft.

NOTE: A mallet and press tool may be used to make sure the gear is seated against the spacer.



Figure 193 - Install locking nut

3. Place the locking nut on the drive shaft, with the nylon ring facing up as shown in Figure 193.



Figure 194 - Install locking nut

4. Screw the locking nut on the drive shaft, hand-tight.

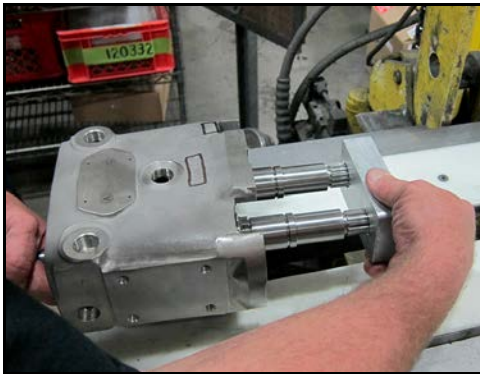

Figure 195 - Block shafts

5. Place the gear case upright, and block the shafts from turning.



Figure 196 - Torque locking nut

6. Place the pump in a press (or use C-clamps) to keep it stationary, and torque the locking nut to the values below.

Table 9: Torque Values - Locking Nut	
015-UTS	15 ft-lb (20 N·m)
030-UTS	30 ft-lb (41 N·m)
130-UTS	45 ft-lb (61 N·m)
220-UTS	75 ft-lb (102 N·m)

Install plugs, sight glass, eye bolts

1. Install the oil breather plug into the hole in the gear case.



Figure 197 - Install oil breather plug

2. Install the oil drain plug O-rings (part number N70114, item 46 on page 98) on the oil drain plugs, then install the drain plugs on the bottom of the pump.
Torque the plugs to 40 in-lb (4.5 N·m).



Figure 198 - Install plugs

3. Install the eye bolts (22) and sight glass (44).

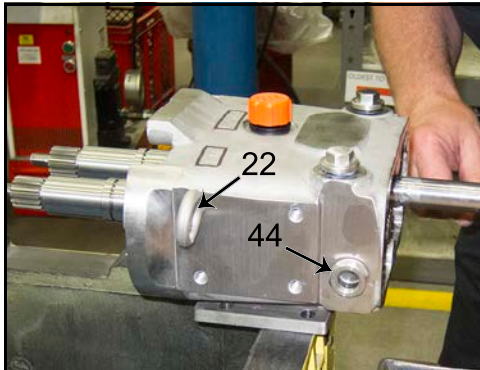

Figure 199 - Install sight glass and eye bolts

Install gear on short shaft

1. Inspect the locking assembly. If the locking assembly was exposed to gear lubricant, remove and clean the locking assembly.

To remove and clean the locking assembly:

- Remove the locking assembly and disassemble it by removing the bolts.
- Clean the parts, removing all oil residues.
- Spray the locking assembly components, including the bolts, with light oil.

NOTE: Do not use oils containing Molybdenum Disulfide.

- Re-assemble the locking assembly.

NOTE: The release threads of the inner ring must be positioned opposite to the un-drilled spaces of the outer ring.

2. Lubricate the locking assembly with light oil and place it in the gear.

NOTE: The bolts on the locking assembly must be loose and lightly oiled. Do not use any oil containing graphite.

NOTE: The gear shown in Figure 200 is from the 220-UTS. The short shaft gears on the 030-UTS and 130-UTS look similar to the 220-UTS, but the gear on the model 015-UTS has a flange in the center of the back of the gear.



Figure 200 - Assemble locking assembly into gear



Figure 201 - Place locking assembly into gear

3. Place the locking assembly into the gear so the back of the locking assembly is even with the back of the gear.

NOTE: On the 015-UTS, the locking assembly seats against the flange.

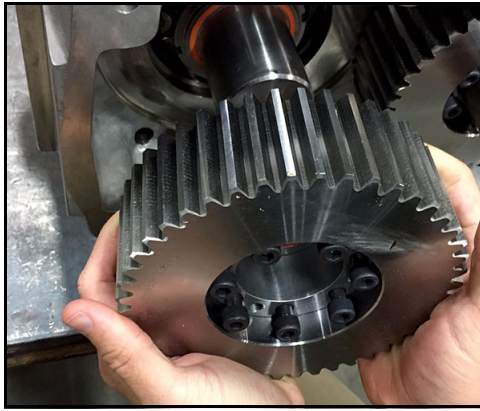

Figure 202 - Install gears onto pump shafts

4. Install the gear onto the pump shaft as shown in Figure 202. Push the gears back until the locking assembly is resting against the locking nut.

NOTE: *On the 015-UTS, push the gears back until the back of the gear is resting against the locking nut.*



Figure 203 - Align loose gear with drive gear

5. Very lightly align the loose gear with the drive gear.

Timing

1. Install the seal caps onto the shafts.

NOTE: Make sure the flats on the seal cap are facing towards the gearcase.



Figure 204 - Install seal caps

2. Install the shafts.



Figure 205 - Install shafts

3. Install the screw nuts (without the O-rings or Belleville washers).



Figure 206 - Install screw nuts

4. Tighten down the screw nuts by hand. Check to ensure that the seal caps are clamped down by the screws. If the seal caps can rotate without rotating the screws, adjust the position of the screws so that both seal caps are fully clamped down and unable to rotate. Finish by firming up the screw nuts with a wrench.

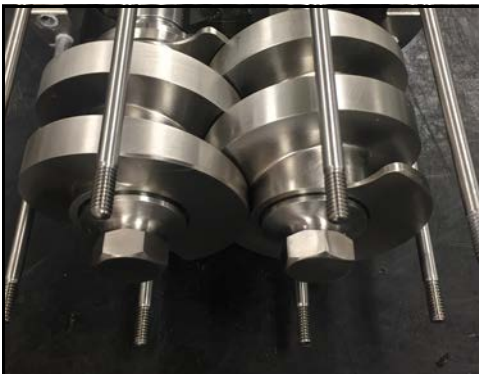

Figure 207 - Tighten screw nuts



Figure 208 - Install screw nuts

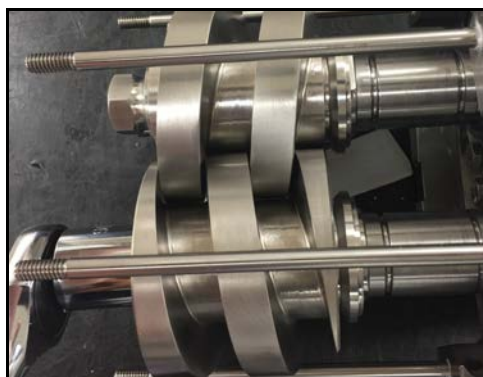

Figure 209 - Install screw nuts



Figure 210 - Measure clearance



Figure 211 - Choose feeler gauge

5. Using a food-grade blocker (for 015, 030, and 130-UTS, see “Screw Blocking Tool” on page 114) to keep the screw from turning, lightly tighten the screw nut.
6. Using a block (for 015, 030, and 130-UTS, see “Screw Blocking Tool” on page 114) on the other screw to keep it from turning, lightly tighten the second screw nut.
7. Rotate the right screw clockwise until it contacts the other screw. With a feeler gauge, measure the open clearance between the screw flanks.
8. Choose a feeler gauge that is equal to half the screw flank clearance measured in step 7.

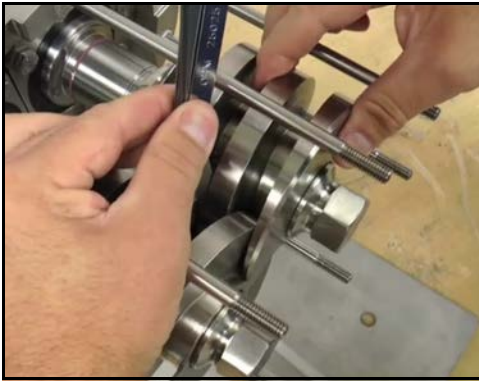

Figure 212 - Rotate screw

9. Insert the feeler gauge selected in step 8 between the screw flanks. Rotate the right screw counter-clockwise until it securely traps the feeler gauge between the screw flanks.



Figure 213 - Align gear

10. Align the loose gear with the drive shaft gear.

NOTE: It may be helpful to recess the loose gear slightly so that when it is tightened down and draws out, it aligns with the drive gear.



Figure 214 - Hand-tighten locking assembly bolts

11. Place a soft dowel in the gear teeth to protect the gears from turning.
12. Hand-tighten the locking assembly bolts in an alternating pattern.

NOTE: To keep the screws timed correctly, it is important to tighten the second gear to the shaft without rotating the shaft.

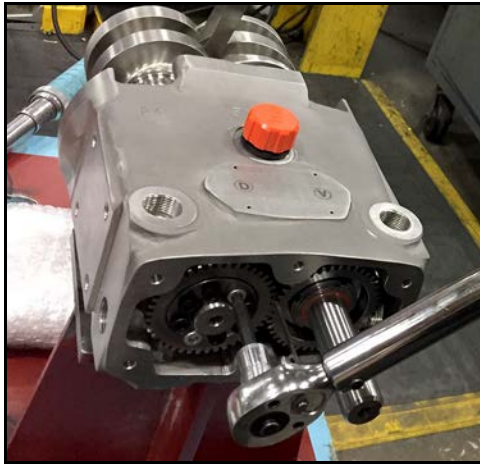

Figure 215 - Torque locking assembly bolts

- In an alternating pattern, torque the locking assembly bolts to half the specified torque, then to the full specified torque. See below.

Table 10: Locking Assembly				
Model	Screw Hex Size	Qty.	Half Torque	Full Torque
015-UTS	5 mm	8	63 in-lb 7 N·m	126 in-lb 14 N·m
030-UTS	5 mm	6	79 in-lb 9 N·m	158 in-lb 18 N·m
130-UTS 220-UTS	6 mm	6	189 in-lb 21 N·m	378 in-lb 43 N·m

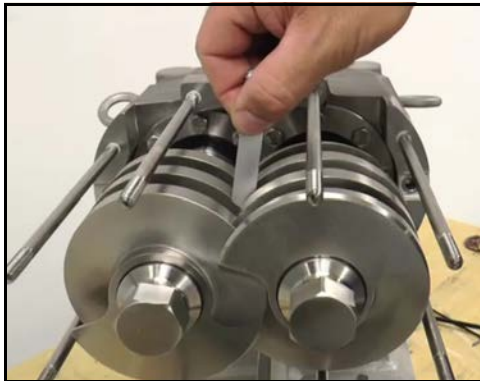

Figure 216 - Confirm the clearance

- Confirm the clearance between the screws is even on the front and back edges of the screw flanks. Turn the drive shaft and ensure that there is no contact at any point. If necessary, re-time the screws.

Assemble and install gear case cover



Figure 217 - Gear case cover components



Figure 218 - Align screw holes

1. Place the gear case cover on a protected surface, inner face, facing up, as shown in Figure 217.
2. Align the holes in the left hand gear shroud (see note below) with the holes in the gear case cover as shown in Figure 218.

NOTE: On the 015-UTS, there is a right and a left gear shroud. On all other sizes, the two shrouds are identical.



Figure 219 - Apply Loctite®

3. Apply Loctite® 242 or equivalent to the shroud screws, and insert them in the holes in the shroud.



Figure 220 - Tighten shroud screws

4. With an Allen wrench, tighten the shroud screws till snug.



Figure 221 - Shrouds installed



Figure 222 - Place gasket on cover

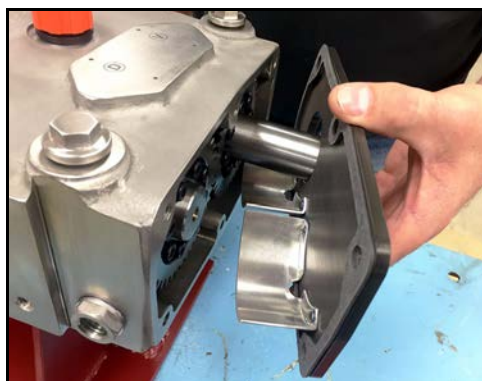

Figure 223 - Install gear case cover



Figure 224 - Apply anti-seize

5. Repeat for the second shroud. Shrouds are shown installed in Figure 221.

6. Place the gear case cover gasket on the gear case cover as shown in Figure 222, aligning the holes in the gasket with the holes in the cover.

NOTE: The gear case cover gasket is designed to compress when the back cover bolts are torqued. If you are re-installing a back cover that has previously been torqued down, replace the gear case cover gasket.

7. Install the gear case cover on the gear case. Slide the shrouds under the gears and the drive shaft hole over the drive shaft. Make sure the gears do not contact the gear shrouds when the cover is in place.

8. Add washers, then apply anti-seize to the gear case cover fasteners.

NOTE: The two socket head shoulder bolts do not have washers.

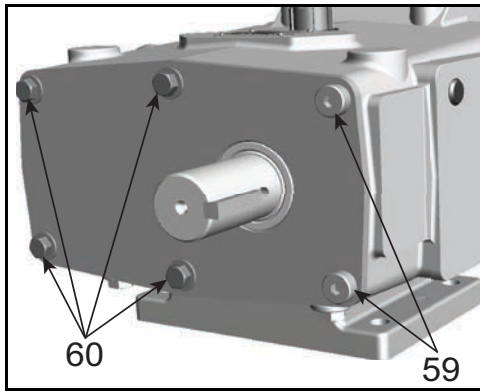

Figure 225 - Install fasteners

9. Install the two socket head shoulder bolts (Figure 225, item 59) in the two holes by the drive shaft, and the four (six on the 220-UTS) hex head cap screws (item 60) in the remaining holes. Snug down the bolts/screws by hand.

10. Before torquing the bolts/screws, turn the drive shaft and ensure that the gears do not contact the gear shrouds.

NOTE: *If there is contact, remove the cover and shift the shrouds as low on the cover as the shroud screw holes allow.*

11. Torque the fasteners in an alternating pattern as specified in Table 11.

Model	HHCS, item 60	SHSB, item 59
015-UTS	88 in-lb (10 N·m)	110 in-lb (12 N·m)
030-UTS	110 in-lb (12 N·m)	132 in-lb (15 N·m)
130-UTS, 220-UTS	132 in-lb (15 N·m)	176 in-lb (20 N·m)



Figure 226 - Install oil seal

12. On the ID of the oil seal, apply lubricant between the lips of the seal.

13. Install the oil seal on the drive shaft.



Figure 227 - Oil seal installed

14. Press the oil seal into the gear case cover, flush with the outside face.

Reference Tables

Pump Model	Oil Capacity	Oil	Change oil
015-UTS	110 ml	Standard: Synthetic Mobil SHC 629-150, part no. 139215+ Food Grade: Synthetic Mobil SHC Cibus-150, part no. 139684+	250 hours, every 2000 hours thereafter*
030-UTS	216 ml		
130-UTS	525 ml		
220-UTS	1575 ml		

* Aggressive washdown or extreme running conditions may require more frequent intervals.



For more information, see "Lubrication" on page 26.

Pump Model	Torque Values - Locknuts		Wrench Size	
	Screw Nut	Cover Nut	Screw Nut	Cover Nut
015-UTS	12 ft-lb 16 N·m	7 ft-lb 10 N·m	15/16"	5/8"
030-UTS	38 ft-lb 52 N·m	11 ft-lb 15 N·m	1-1/4"	
130-UTS	88 ft-lb 119 N·m	25 ft-lb 34 N·m	1-5/8"	7/8"
220-UTS	200 ft-lb 271 N·m	55 ft-lb 75 N·m	2-1/4"	

Torque Values - Gear Case				
Pump Model	Bearing Retainer Screws	Locking Nut	Gear Case Cover Fasteners	
			HHCS	SHSB
015-UTS	24 in-lb (2 ft-lb) 3 N·m	15 ft-lb 20 N·m	88 in-lb 10 N·m	110 in-lb 12 N·m
030-UTS	84 in-lb (7 ft-lb) 9 N·m	30 ft-lb 41 N·m	110 in-lb 12 N·m	132 in-lb 15 N·m
130-UTS	180 in-lb (15 ft-lb) 20 N·m	45 ft-lb 61 N·m	132 in-lb 15 N·m	176 in-lb 20 N·m
220-UTS	300 in-lb (25 ft-lb) 34 N·m	75 ft-lb 102 N·m		

Torque Values - Locking Assembly				
Pump Model	Screw Hex Size	Qty.	Half Torque	Full Torque
015-UTS	5 mm	8	63 in-lb 7 N·m	126 in-lb 14 N·m
030-UTS	5 mm	6	79 in-lb 9 N·m	158 in-lb 18 N·m
130-UTS, 220-UTS	6 mm	6	189 in-lb 21 N·m	378 in-lb 43 N·m

Table 12: Standard O-Ring Selections, Descriptions and Color Codes for WCB Brand Pumps

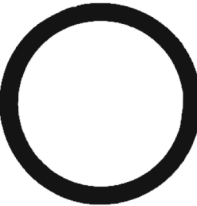
<p>Ethylene Propylene Diene Rubber (EPDM) Compound Color: Black or Purple Color Code: Green FDA Compliant to 21CFR177.2600</p>		<p>Fluorocarbon Rubber (FKM) Compound Color: Rust, Brown or Black Color Code: White FDA Compliant to 21CFR177.2600 3-A Sanitary</p>	
<p>Ethylene Propylene Diene Rubber (Sulfur Free) (EPDM) Compound Color: Black or Purple Color Code: Blue FDA Compliant to 21CFR177.2600</p>		<p>Perfluoroelastomer (FFKM) Compound Color: Black Color Code: None Individually packaged with size and material noted.</p>	

Troubleshooting

PROBLEM	POSSIBLE CAUSE	SUGGESTED ACTION
No flow, pump screws are not turning	Drive motor not running.	Check resets, fuses, circuit breakers.
	Keys sheared or missing.	Replace.
	Drive belts, power transmission components slipping or broken.	Replace or adjust.
	Pump shaft, keys, or gears sheared.	Inspect: and replace parts as necessary.
	Screws not properly timed	Check clearances between screw flanks. Re-time if necessary.
No flow, pump screws are turning	Screws turn in the wrong direction.	Check motor hookup to reverse motor rotation.
	Relief valve not properly adjusted, or held open by foreign material.	Adjust or clear valve.
	Suction port is blocked, not allowing flow to the pump.	Check all inlet valves, strainers, tank outlet ports.
	Slip too high	Check flow-speed curve (available from SPX FLOW website) and adjust as necessary.
No flow, pump not priming	Valve closed in inlet line.	Open valve.
	Inlet line clogged or restricted.	Clear line, clean filters, etc.
	Air leaks due to bad gaskets or pipe connections.	Replace gaskets; check lines for leakage (can be done by air pressure or by filling with liquid and pressurizing with air).
	Pump speed too slow.	Increase pump speed.
	Pump speed too fast for high-viscosity liquid.	Decrease pump speed.
	Liquid drains or siphons from system during off periods.	Use foot valve or check valves. Filling inlet lines with material before startup may solve startup priming problems due to no material in system.
	“Air” lock caused by fluids which “gas off,” or vaporize, or allow gas to come out of solution during off periods.	Install and use a manual or automatic air bleed from pump or lines near pump.
	Worn screws	Increase pump speed, use foot valve or check valve to improve priming. Make sure inlet and discharge are not restricted. Replace worn screws.

PROBLEM	POSSIBLE CAUSE	SUGGESTED ACTION
No flow, pump not priming, cont'd	Net inlet pressure available too low.	Check Net Inlet Pressure Available & Net Inlet Pressure Required. Change inlet system as needed.
	On "Vacuum" inlet system: On initial start-up, atmospheric "blow back" prevents pump from developing enough differential pressure to start flow.	Install check valve in discharge line.
	Motor incorrectly sized for the application	Contact SPX FLOW Application Engineering
Insufficient flow	Speed too low or too high to obtain desired flow.	Check flow-speed curve (available from SPX FLOW website) and adjust as necessary.
	Net inlet pressure available too low.	Check Net Inlet Pressure Available & Net Inlet Pressure Required. Change inlet system as needed.
	Air leak due to bad seals, pipe connections, or other equipment.	Replace seals, check inlet fittings.
Insufficient flow—flow being bypassed somewhere	Flow diverted in branch line, open valve, etc.	Check system and controls
	Relief valve not adjusted or jammed.	Clear or adjust valve.
Insufficient flow—high slip	Worn pump.	Increase pump speed (within limits). Replace screws, have pump remanufactured.
	High pressure.	Reduce pressure by adjusting system settings or hardware.
Fluid vaporization ("starved" pump inlet)	Strainers, foot valves, inlet fittings or lines clogged.	Clear lines. If problem continues, inlet system may require changing.
	Inlet line size too small, inlet line too long. Too many fittings or valves. Foot valve, strainers too small.	Increase inlet line size. Reduce length, minimize direction and size changes, reduce number of fittings.
	NIPA - Net Inlet Pressure Available at Pump is too low.	Raise liquid level in source tank to increase Net Inlet Pressure (NIPA).
		Increase Net Inlet Pressure Available at Pump by raising or pressurizing source tank.
		Select larger pump size with lower Net Inlet Pressure Required.
		Select a set of screws with a narrower pitch to lower the Net Inlet Pressure Required (NIPR)

PROBLEM	POSSIBLE CAUSE	SUGGESTED ACTION
	Fluid viscosity greater than expected.	Reduce pump speed and accept lower flow, or change system to reduce line losses. Change temperature of product to reduce viscosity.
	Fluid temperature higher than expected (vapor pressure higher).	Reduce temperature, reduce speed and accept lower flow or change system to increase Net Inlet Pressure Available.
Noisy operation	Cavitation	
	High fluid viscosity. High vapor pressure fluid. High temperature.	Slow down pump, reduce temperature, change system setup.
	Net Inlet Pressure Available less than Net Inlet Pressure Required.	Increase NIPA - Net Inlet Pressure Required or reduce NIPR - Net Inlet Pressure Required. Contact SPX FLOW if necessary.
	Air or gas in fluid	
	Leaks in the pump or piping.	Correct leaks.
	Dissolved gas or naturally aerated products.	Minimize discharge pressure (also see "Cavitation," above).
Noisy operation caused by mechanical problems	Screw to body contact	
	Improper assembly of pump.	Check clearances
	Distortion of pump due to improper piping installation.	Change piping installation to eliminate piping stress and distortion on body.
	Pressures required higher than the pump is rated for.	Reduce discharge pressure required.
	Worn bearings.	Rebuild with new bearings and lubricate regularly.
	Screw to Screw Contact	
	Loose or incorrectly-timed gears.	This has caused severe damage to components - rebuild with new parts.
	Sheared keys.	This has caused severe damage to components - rebuild with new parts.
	Worn gear splines.	This has caused severe damage to components - rebuild with new parts.
	Drive noise caused by gear trains, chains, couplings, bearings.	Repair or replace drive parts. Check bearings for damage and replace as necessary.

PROBLEM	POSSIBLE CAUSE	SUGGESTED ACTION
Pump requires excessive power (overheats, stalls, high current draw, breakers trip)	Higher than expected viscosity losses.	If within pump rating, increase drive size.
	Higher than expected pressures.	Reduce pump speed. Increase line sizes.
	Fluid is colder with a higher viscosity than expected.	Heat fluid, insulate lines or heat trace lines. Increase line sizes.
Pump requires excessive power, cont'd	Fluid sets in line and pump during shutdown.	Insulate lines or heat trace lines. Install a "soft start" drive. Install a recirculating bypass system. Flush system with a nonsetting fluid.
	Fluid builds up on pump surfaces.	Replace the pump with more running clearances.
Short pump service life	Pumping abrasives	Larger pumps at slower speeds.
	Speeds and pressures higher than rated.	Reduce speeds and pressures by making changes in the system. Replace pump with a larger model with higher pressure ratings.
	Worn bearings and gears due to lack of lubrication.	Check and replace bearing and gears as necessary. Adjust lubrication schedule to decrease time between lubrication. Modify external wash down method to reduce water entering into gear case.
	Misalignment of drive and piping. (Excessive overhung load or misaligned couplings.)	Check alignment of piping and drive. Adjust as necessary.

Long Term Storage

Long-term storage (greater than six months) of Waukesha Cherry-Burrell brand pumps:

Before Storage

1. Lubricate all bearings and seals, including:
 - Rubber o-rings and mechanical seal faces (new pump bearings installed from the factory are already lubricated).
 - Motors and drives (see manufacturer's instructions)
2. Be sure the pump contains no water. Make sure to disassemble the wet end and wipe it dry if necessary.
3. Use rust inhibitor on any exposed metal surfaces:
 - Any unpainted surfaces
 - Shafts, nuts/bolts
4. Cover the inlet/outlet connections of the pumps to keep out foreign materials.
5. Put all related instruction manuals in a separate water-tight envelope or container and store them with the equipment.
6. Completely enclose the equipment to prevent contamination from moisture, dust and other possible contaminants. Certain types of plastic wrap materials, when properly used, make excellent storage enclosures.
7. Rotate the pump and drive shafts several turns every 3 months.

Storage

1. Store in a dry location. Indoor storage is preferred. If stored outdoors, the equipment must be in a weather-tight enclosure and shielded from direct sunlight.
2. Maintain even temperatures to prevent condensation.

After Storage

NOTE: Do not start the motor if there is any indication of water contamination. Have the motor checked by a qualified electrician before starting.

1. Remove the equipment from the enclosure and repair or replace any damaged items before using equipment.
2. Check the electric motor (if applicable) per the manufacturer's instructions.
3. Pumps:
 - Completely disassemble the product contact liquid end per the instruction manual.
 - Clean and inspect all parts, including seals and o-rings.
 - Replace rubber parts with any sign of age or damage, such as cracks, taking a set, or loss of elasticity.
4. Lubricate the seal and o-rings and reassemble the liquid end per the instruction manual.
5. Lubricate the motor/drive (if applicable) per the manufacturer's instructions.
6. If the pump has been in storage longer than 1 year, change the oil in the pump and drive.

Pump Dimensions

Universal Twin Screw PD Pump Dimensions

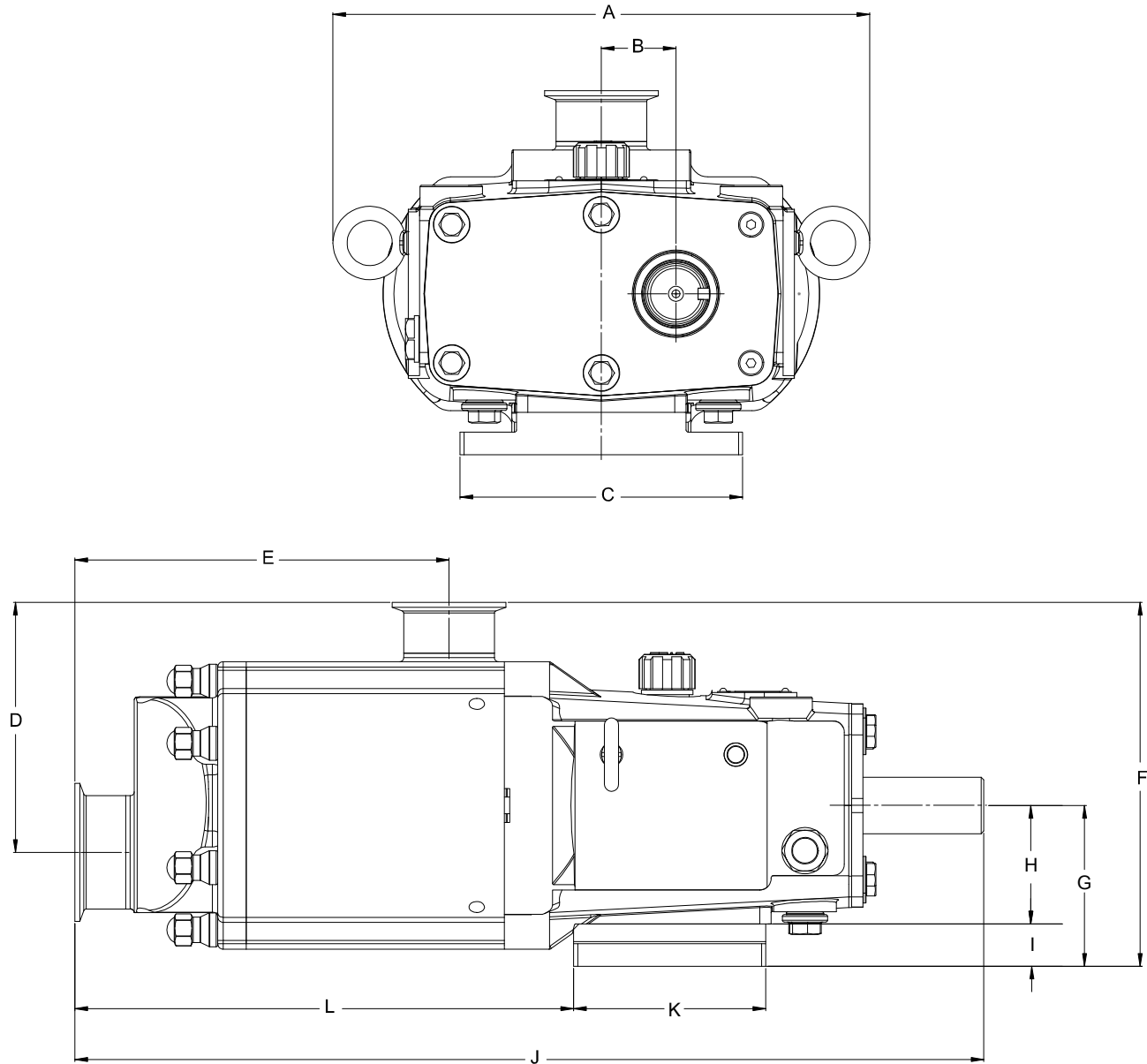

SIZE		A	B	C	D	E	F	G	H	I	J	K	L
015-TS	in	9.678	1.281	4.741	4.567	6.400	6.775	2.933	2.120	0.813	16.666	3.741	8.859
	mm	245.82	32.54	120.42	116.00	162.56	172.09	74.50	53.85	20.65	423.32	95.02	225.02
030-TS	in	11.874	1.650	6.250	5.530	8.278	8.049	3.558	2.620	0.938	20.107	4.250	11.032
	mm	301.60	41.91	158.75	140.46	210.26	204.44	90.37	66.55	23.83	510.72	107.95	280.21
130-TS	in	16.375	2.250	8.250	6.704	10.520	10.685	5.063	3.500	1.563	25.809	5.875	14.680
	mm	415.93	57.15	209.55	170.28	267.21	271.40	128.60	88.90	39.70	655.55	149.23	372.87
220-TS 4"H x 4"V	in	20.400	3.000	8.500	11.600	15.600	15.700	6.400	4.500	1.900	33.800	9.000	19.000
	mm	518.16	76.20	215.90	294.64	396.24	398.78	162.56	114.30	48.26	858.52	228.60	482.60
220-TS 4"H x 6"V	in	20.400	3.000	8.500	12.600	15.600	16.700	6.400	4.500	1.900	33.800	9.000	19.000
	mm	518.16	76.20	215.90	320.04	396.24	424.18	162.56	114.30	48.26	858.52	228.60	482.60
220-TS 6"H x 4"V	in	20.400	3.000	8.500	10.600	16.000	15.700	6.400	4.500	1.900	34.200	9.000	19.400
	mm	518.16	76.20	215.90	269.24	406.40	398.78	162.56	114.30	48.26	868.68	228.60	492.76
220-TS 6"H x 6"V	in	20.400	3.000	8.500	11.600	16.000	16.700	6.400	4.500	1.900	34.200	9.000	19.400
	mm	518.16	76.20	215.90	294.64	406.40	424.18	162.56	114.30	48.26	868.68	228.60	492.76

NOTE: In the table, H=Horizontal port and V=Vertical port.

Pump Shaft Guards

⚠ WARNING

Full guards must be installed to isolate operators and maintenance personnel from rotating components.

Guards are provided as part of a complete pump and drive package and are selected by SPX FLOW Engineering for the pump, base, and motor ordered. Do not modify the guard provided by SPX FLOW. If the guard provided by SPX FLOW is lost, contact SPX FLOW Customer Service and provide your order number or PO number of the pump to order a correctly-sized replacement guard.

If the pump was not purchased as a unit, it is the responsibility of the customer to ensure proper guarding. Refer to your local regulations for guidance.

Guard (side view) shown as supplied with an SPX FLOW base package

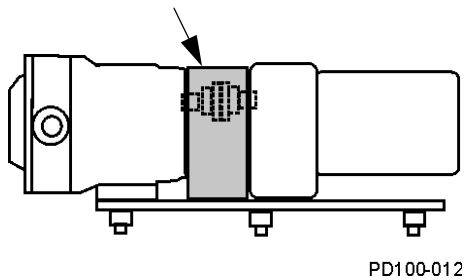

Top view

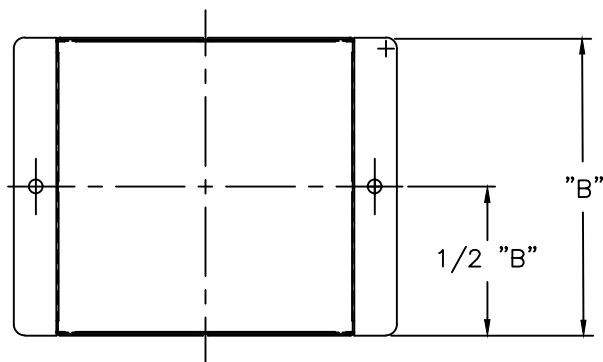

Front view

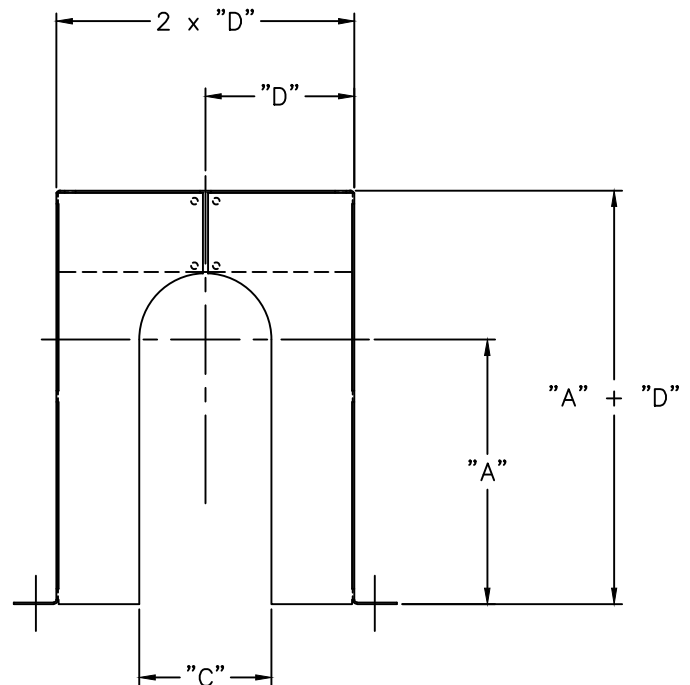

NOTE: Dimensions A, B, C, and D depend on the specific pump unit configuration.

Parts List

015-UTS Parts

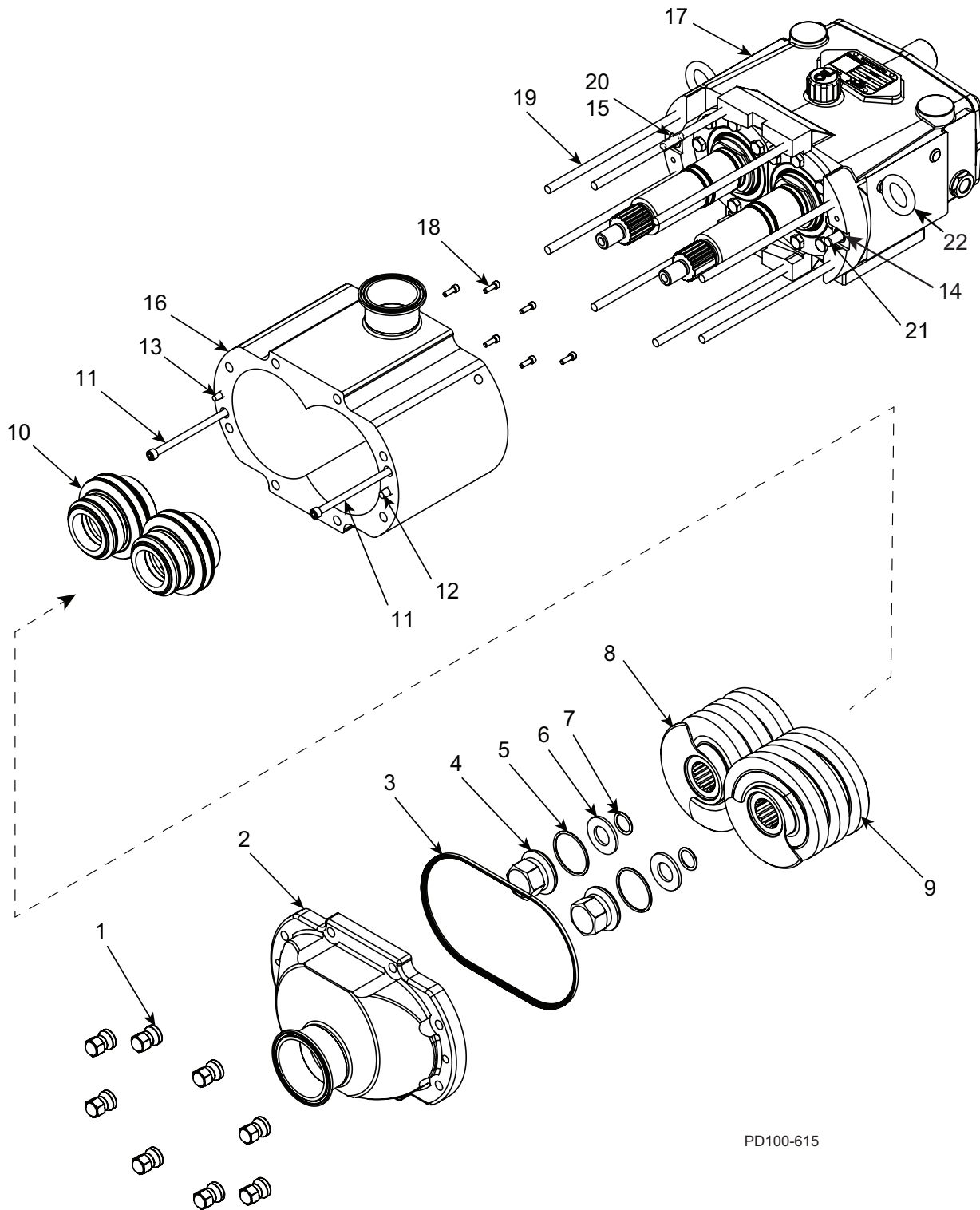

PD100-615

015-UTS Parts

ITEM NO.	DESCRIPTION	QTY PER PUMP	PART NO.	NOTES
1	Nut, Acorn	8	109369+	
2	Cover	1	POA	
* 3	Gasket, Cover, EPDM	1	137424+	
	Gasket, Cover, FKM		137422+	
	Gasket, Cover, FFKM		137423+	
4	Nut, Screw	2	101804+	
* 5	Screw Nut O-ring EPDM	2	E70126	
	Screw Nut O-ring FKM		V70126	
	Screw Nut O-ring FFKM		K70126	
6	Washer-Belleville	2	101691+	
* 7	Washer Retainer O-ring EPDM	2	E70112	
	Washer Retainer O-ring FKM		V70112	
	Washer Retainer O-ring FFKM		K70112	
8	Left Hand Screw 16.5 Pitch	1	137363+	
	Left Hand Screw 33 Pitch		136792+	
	Left Hand Screw 44 Pitch		137365+	
9	Right Hand Screw 16.5 Pitch	1	137362+	
	Right Hand Screw 33 Pitch		136791+	
	Right Hand Screw 44 Pitch		137364+	
10	Mechanical Seal Assembly	2	POA	1
11	Body Retaining Screw	2	137096+	
12	Cover Short Dowel Pin	1	137002+	
13	Cover Short Dowel Pin	1	137001+	
14	Bushing, Dowel Pin	1	AD0116100	
15	Bushing, Dowel Pin	1	AD0116000	
16	Pump Body	1	POA	
17	Gear Case Assy	1	POA	
18	SHCS 6-32 x .375 18-8 SS	6	119627+	
19	Stud, Standard Cover	8	137068+	
20	Gear Case Dowel	1	124581+	
21	Gear Case Dowel	1	124582+	
22	Eye Bolt 5/16-18 X .50"LG 304	2	30-719	

PL5060-CH139

Notes:

* Recommended spare part

1. See "Universal Twin Screw Seal Parts" on page 113.

POA: Contact customer service for part number.

015-UTS Parts, continued

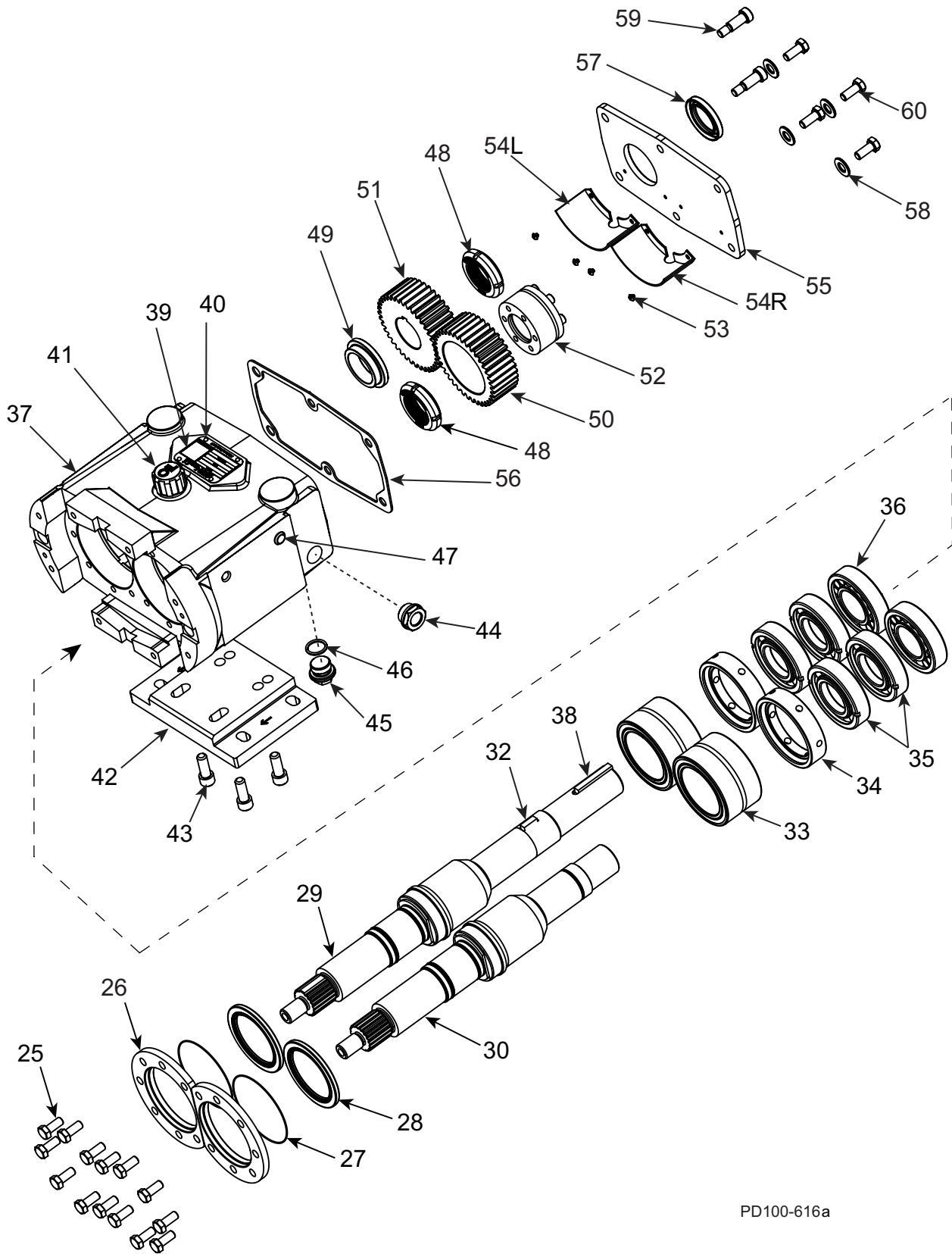

PD100-616a

015-UTS Parts, continued

ITEM NO.	DESCRIPTION	QTY PER PUMP	PART NO.	NOTES
25	HHCS 1/4-20 X .75 18-8SS	14	30-58	
26	Bearing Retainer	2	137542+	
27	Bearing Retainer O-Ring	2	138856+	
28	Seal, Bearing	2	121679+	
29	Shaft-Drive 17-4 PH	1	136826+	
30	Shaft-Short 17-4 PH	1	136827+	
32	Gear Key	1	015037000+	
33	Needle Roller Bearing	2	137550+	
34	Spacer, Bearing	2	137546+	
35	Four Point Angular Contact Brg.	4	137554+	
36	Cylindrical Roller Brg.	2	137558+	
37	Gear Case - Stainless Stl.	1	136838+	
38	Key .187 x .187 x 1.125	1	000037001+	
39	Nameplate - QR Code	1	135623+	
40	RHDS #2 x .125	4	30-355	
41	Breather Plug-Oil	1	115800+	
42	Gear Case Shim, SS (Mounting Foot)	1	102284+	
43	SHCS 5/16-18x1.00 SS	4	30-525	
44	Oil Sight Glass - SS	1	137435+	
45	Plug-Drain/Level M20x1.5	2	137169+	
* 46	O-Ring Buna	2	N70114	
47	Plug 5/16" Plastic	2	000121003+	
48	Locking Nut	2	137566+	
49	Spacer-Gear	1	138978+	
50	Gear, Short Shaft, Spur	1	137672+	
51	Gear, Drive Shaft, Spur	1	107997+	
52	Locking Assembly	1	137663+	
53	BHSC Screw 6-32UNC .125 18-8 SS	4	139157+	
54L	Shroud, Gear, 015UTS-LH	1	139155+	
54R	Shroud, Gear, 015UTS-RH	1	139146+	
55	Cover, Gear Case	1	139135+	
56	Gasket, Gear Case/Cover	1	138519+	
57	Oil Seal, Gear Case Cover	1	000030016+	
58	Washer Plain 3/8 18-8 Narrow	4	43-27	
59	SHSB 5/16" X .75"LG 18-8	2	30-690	
60	HHCS 1/4-20 X .75 18-8SS	4	30-58	

PL5060-CH140

Notes:

* Recommended Spare Parts

030-UTS Parts

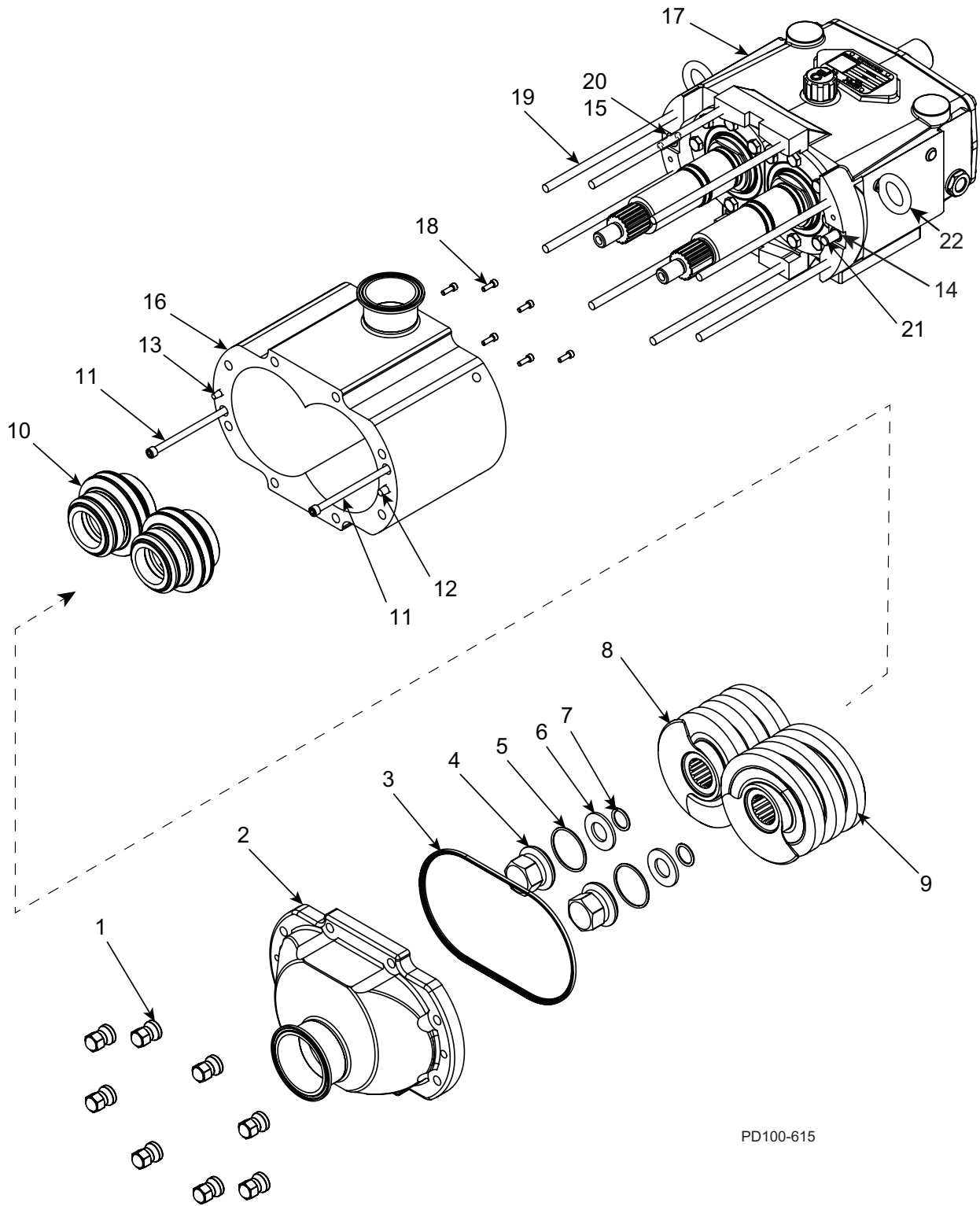

PD100-615

030-UTS Parts

ITEM NO.	DESCRIPTION	QTY PER PUMP	PART NO.	NOTES
1	Nut, Acorn	8	108370+	
2	Cover	1	POA	
* 3	Gasket, Cover, EPDM	1	137427+	
	Gasket, Cover, FKM		137425+	
	Gasket, Cover, FFKM		137426+	
4	Nut, Screw	2	101805+	
* 5	Screw Nut O-ring EPDM	2	E70130	
	Screw Nut O-ring FKM		V70130	
	Screw Nut O-ring FFKM		K70130	
6	Washer-Belleville	2	101692+	
* 7	Washer Retainer O-ring EPDM	2	E70115	
	Washer Retainer O-ring FKM		V70115	
	Washer Retainer O-ring FFKM		K70115	
8	Left Hand Screw - 16.8 Pitch	1	137367+	
	Left Hand Screw - 28 Pitch		136795+	
	Left Hand Screw - 42 Pitch		137369+	
9	Right Hand Screw - 16.8 Pitch	1	137366+	
	Right Hand Screw - 28 Pitch		136794+	
	Right Hand Screw - 42 Pitch		137368+	
10	Mechanical Seal Assembly	2	POA	1
11	Body Retaining Screw	2	137097+	
12	Cover Short Dowel Pin	1	137002+	
13	Cover Short Dowel Pin	1	137001+	
14	Bushing, Dowel Pin	1	BD0116100	
15	Bushing, Dowel Pin	1	BD0116000	
16	Pump Body	1	POA	
17	Gear Case Assy	1	POA	
18	SHCS 8-32 x .500" 18-8SS	6	137460+	
19	Stud, Standard Cover	8	137069+	
20	Gear Case Dowel	1	124582+	
21	Gear Case Dowel	1	124583+	
22	Eye Bolt 3/8-16 X .56"LG 304	2	30-720	

PL5060-CH141

Notes:

* Recommended spare part

1. See "Universal Twin Screw Seal Parts" on page 113.

POA: Contact customer service for part number.

030-UTS Parts, continued

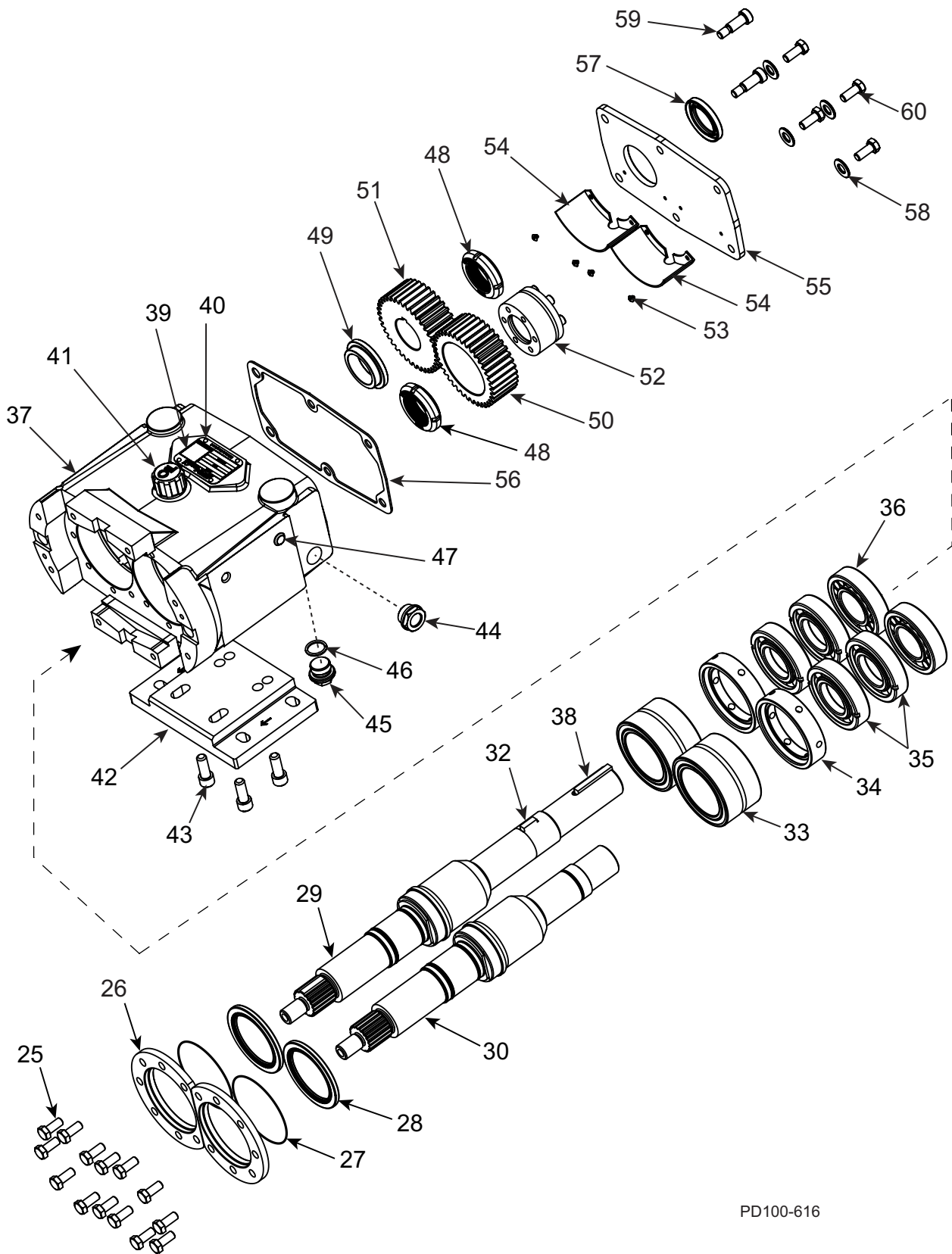

PD100-616

030-UTS Parts, continued

ITEM NO.	DESCRIPTION	QTY PER PUMP	PART NO.	NOTES
25	HHCS 5/16-18 X.75" LG 304	14	30-623	
26	Bearing Retainer	2	137543+	
27	Bearing Retainer O-Ring	2	138857+	
28	Seal, Bearing	2	121680+	
29	Shaft-Drive 17-4 PH	1	136828+	
30	Shaft-Short 17-4 PH	1	136829+	
32	Gear Key	1	BD0037000	
33	Needle Roller Bearing	2	137551+	
34	Spacer, Bearing	2	137547+	
35	Four Point Angular Contact Brg.	4	137555+	
36	Cylindrical Roller Brg.	2	137559+	
37	Gear Case - Stainless Stl.	1	136840+	
38	Key, .250 x .250 x 1.750	1	000037002+	
39	Nameplate - QR Code	1	135624+	
40	RHDS #2 x .125	4	30-355	
41	Breather Plug-Oil	1	115800+	
42	Gear Case Shim, SS (Mounting Foot)	1	102285+	
43	SHCS 3/8-16x1.00 18-8 SS	4	30-189	
44	Oil Sight Glass - SS	1	137435+	
45	Plug-Drain/Level M20x1.5	2	137169+	
* 46	O-Ring Buna	2	N70114	
47	Plug 3/8" Plastic	2	000121002+	
48	Locking Nut	2	137567+	
49	Spacer-Gear	1	138979+	
50	Gear, Short Shaft, Spur	1	108000+	
51	Gear, Drive Shaft, Spur	1	107999+	
52	Locking Assembly	1	108784+	
53	BHSC Screw 6-32UNC .125 18-8 Ss	4	139157+	
54	Shroud, Gear	2	139141+	
55	Cover, Gear Case	1	139137+	
56	Gasket, Gear Case/Cover	1	138520+	
57	Oil Seal, Gear Case Cover	1	000030013+	
58	Washer Plain 3/8 18-8 Narrow	4	43-30	
59	SHSB 3/8" X .75" Lg 18-8	2	30-691	
60	HHCS 5/16-18 X.75" LG 304	4	30-623	

PL5060-CH142

Notes:

* Recommended Spare Parts

130-UTS Parts

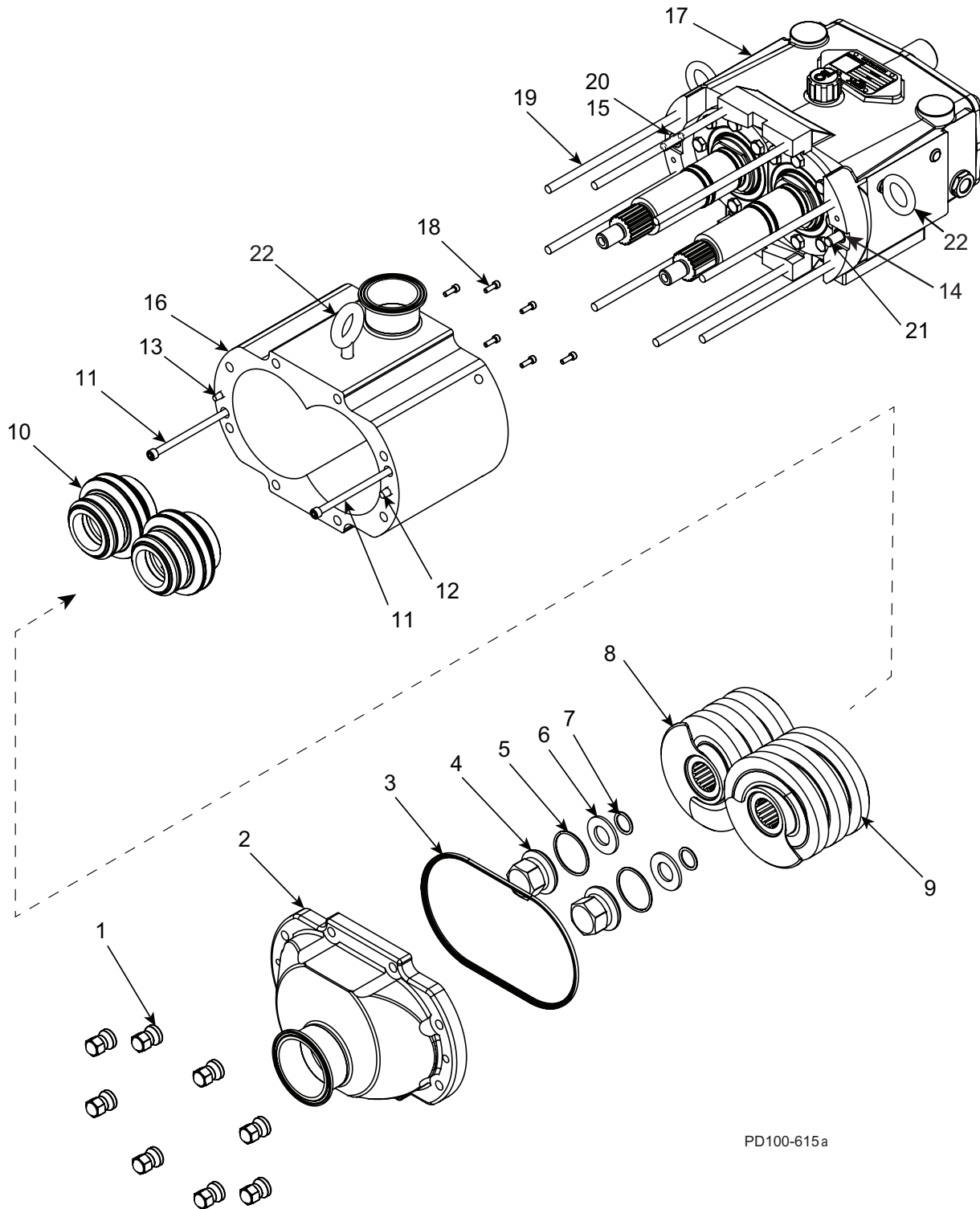

PD100-615a

130-UTS Parts

ITEM NO.	DESCRIPTION	QTY PER PUMP	PART NO.	NOTES
1	Nut, Acorn	8	108371+	
2	Cover	1	POA	
* 3	Gasket, Cover, EPDM	1	137430+	
	Gasket, Cover, FKM		137428+	
	Gasket, Cover, FFKM		137429+	
4	Nut, Screw	2	101806+	
* 5	Screw Nut O-ring EPDM	2	E70227	
	Screw Nut O-ring FKM		V70227	
	Screw Nut O-ring FFKM		K70227	
6	Washer-Belleville	2	101693+	
* 7	Washer Retainer O-ring EPDM	2	E70119	
	Washer Retainer O-ring FKM		V70119	
	Washer Retainer O-ring FFKM		K70119	
8	Left Hand Screw - 36.7 Pitch	1	137371+	
	Left Hand Screw - 55 Pitch		136798+	
	Left Hand Screw - 73.4 Pitch		137373+	
9	Right Hand Screw - 36.7 Pitch	1	137370+	
	Right Hand Screw - 55 Pitch		136797+	
	Right Hand Screw - 73.4 Pitch		137372+	
10	Mechanical Seal Assembly	2	POA	1
11	Body Retaining Screw	2	132089+	
12	Cover Short Dowel Pin	1	137003+	
13	Cover Short Dowel Pin	1	137002+	
14	Bushing, Dowel Pin	1	CD0116100	
15	Bushing, Dowel Pin	1	CD0116000	
16	Pump Body	1	POA	
17	Gear Case Assy	1	POA	
18	SHCS 10-32x.50 18-8 SS	6	30-243	
19	Stud, Standard Cover	8	137070+	
20	Gear Case Dowel	1	124584+	
21	Gear Case Dowel	1	124586+	
22	Eye Bolt 1/2-13 X .75"LG 304	3	30-721	

PL5060-CH143

Notes:

* Recommended spare part

1. See "Universal Twin Screw Seal Parts" on page 113.

POA: Contact customer service for part number.

130-UTS Parts, continued

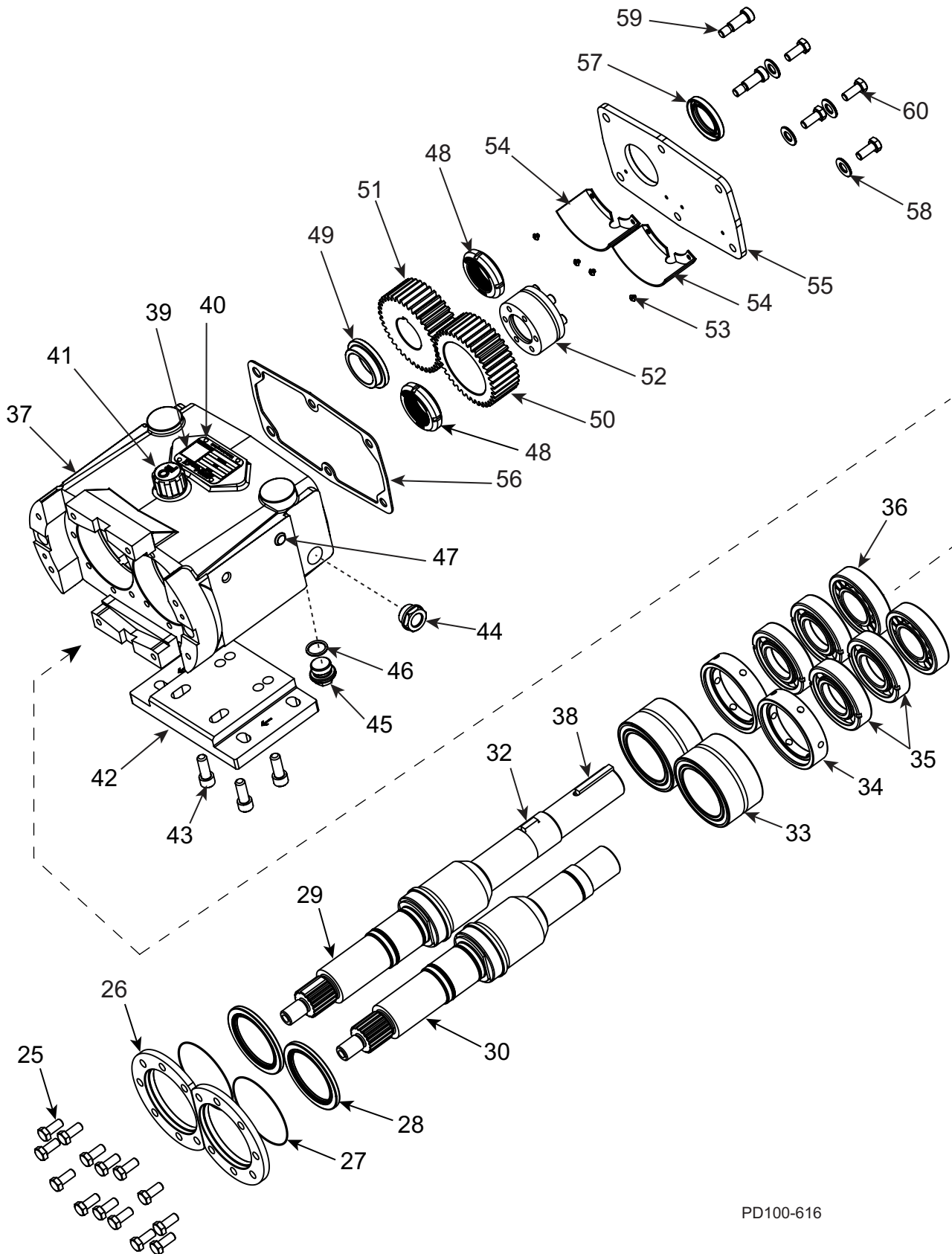

PD100-616

130-UTS Parts, continued

ITEM NO.	DESCRIPTION	QTY PER PUMP	PART NO.	NOTES
25	HHCS 3/8-16 X 1.25 18-8 SS	14	30-60	
26	Bearing Retainer	2	137544+	
27	Bearing Retainer O-Ring	2	138858+	
28	Seal, Bearing	2	101829+	
29	Shaft-Drive 17-4 PH	1	136830+	
30	Shaft-Short 17-4 PH	1	136831+	
32	Gear Key	1	060037000+	
33	Needle Roller Bearing	2	137552+	
34	Spacer, Bearing	2	137548+	
35	Four Point Angular Contact Brg.	4	137556+	
36	Cylindrical Roller Brg.	2	137560+	
37	Gear Case - Stainless Stl.	1	136842+	
38	Key .375 x .375 x 1.625	1	000037003+	
39	Nameplate - QR Code	1	135624+	
40	RHDS #2 x .125	4	30-355	
41	Breather Plug-Oil	1	115800+	
42	Gear Case Shim, SS (Mounting Foot)	1	102286+	
43	SHCS 1/2-13x1.25"LG 18-8	4	30-503	
44	Oil Sight Glass - SS	1	137435+	
45	Plug-Drain/Level M20x1.5	2	137169+	
* 46	O-Ring Buna	2	N70114	
47	Plug 1/2" Plastic	2	000121001+	
48	Locking Nut	2	137568+	
49	Spacer-Gear	1	138980+	
50	Gear, Short Shaft, Spur	1	107405+	
51	Gear, Drive Shaft, Spur	1	138508+	
52	Locking Assembly	1	108785+	
53	BHSC Screw 6-32UNC .125 18-8 SS	4	139157+	
54	Shroud, Gear	2	139147+	
55	Cover, Gear Case	1	139139+	
56	Gasket, Gear Case/Cover	1	138521+	
57	Oil Seal, Gear Case Cover	1	000030012+	
58	Washer Plain 3/8 18-8 Narrow	4	43-30	
59	SHSB 1/2" X 1.0" 18-8	2	30-692	
60	HHCS 3/8-16 x .75" 18-8	4	30-50	

PL5060-CH144

Notes:

* Recommended Spare Parts

220-UTS Parts

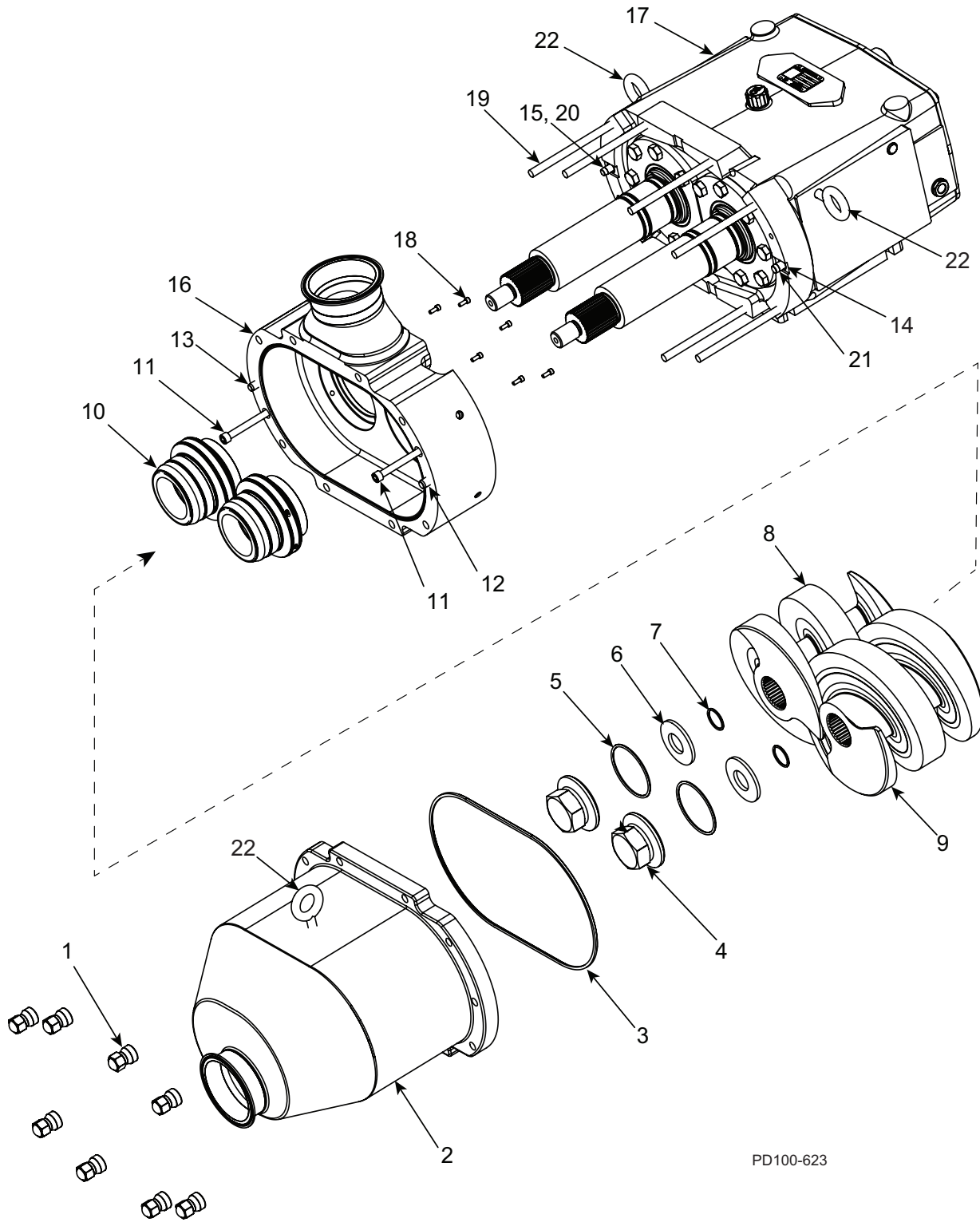

PD100-623

220-UTS Parts

ITEM NO.	DESCRIPTION	QTY PER PUMP	PART NO.	NOTES
1	Nut, Acorn	8	108372+	
2	Cover	1	POA	
3	Gasket, Cover, EPDM	1	137433+	2
	Gasket, Cover, FKM		137431+	
	Gasket, Cover, FFKM		137432+	
4	Nut, Screw	2	137608+	
* 5	Screw Nut O-ring EPDM	2	E70235	
	Screw Nut O-ring FKM		V70235	
	Screw Nut O-ring FFKM		K70235	
6	Washer-Belleville	2	101694+	
* 7	Washer Retainer O-ring EPDM	2	E70122	
	Washer Retainer O-ring FKM		V70122	
	Washer Retainer O-ring FFKM		K70122	
8	Left Hand Screw - 45 Pitch	1	137375+	
	Left Hand Screw - 60 Pitch		136801+	
	Left Hand Screw - 90 Pitch		137377+	
9	Right Hand Screw - 45 Pitch	1	137374+	
	Right Hand Screw - 60 Pitch		136800+	
	Right Hand Screw - 90 Pitch		137376+	
10	Mechanical Seal Assembly	2	POA	1
11	Body Retaining Screw	2	137099+	
12	Cover Short Dowel Pin	1	137005+	
13	Cover Short Dowel Pin	1	137004+	
14	Bushing, Dowel Pin	1	CD0116100	
15	Bushing, Dowel Pin	1	CD0116000	
16	Pump Body	1	POA	
17	Gear Case Assy	1	POA	
18	SHCS 10-32x.50 18-8 SS	6	30-243	
19	Stud, Standard Cover	8	108844+	
20	Gear Case Dowel	1	124584+	
21	Gear Case Dowel	1	124586+	
22	Eye Bolt 1/2-13 x .75 304SS	3	30-721	

PL5060-CH145

Notes:

* Recommended spare part

1. See "Universal Twin Screw Seal Parts" on page 113.
 2. On the 220-UTS, this gasket is installed in the body, not the cover.
- POA: Contact customer service for part number.

220-UTS Parts, continued

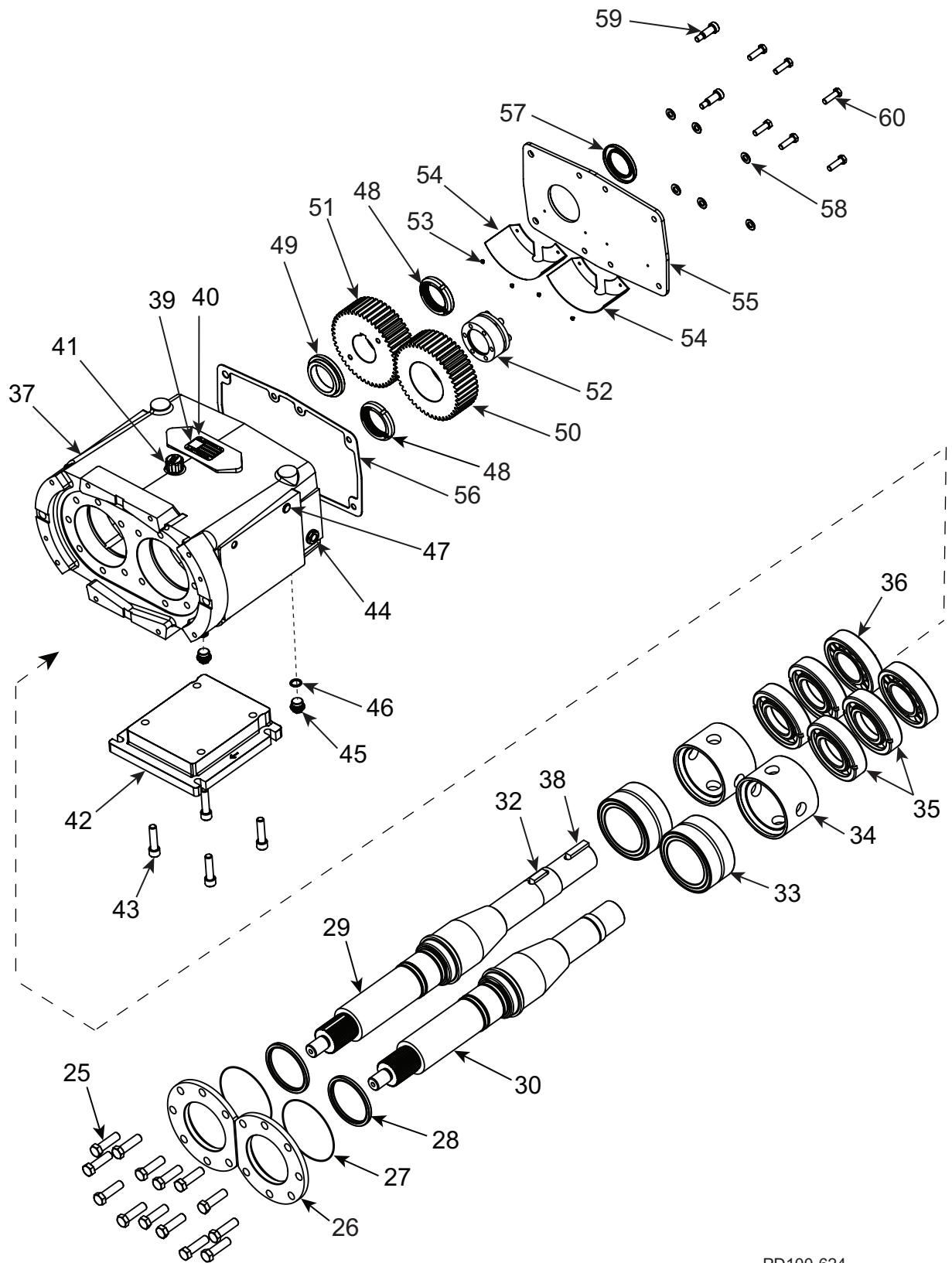

PD100-624

220-UTS Parts, continued

ITEM NO.	DESCRIPTION	QTY PER PUMP	PART NO.	NOTES
25	HHCS 9/16-12 X 2.00 18-8 SS	14	30-731	
26	Bearing Retainer	2	137545+	
27	Bearing Retainer O-Ring	2	138859+	
28	Seal, Bearing	2	121681+	
29	Shaft-Drive 17-4 PH	1	136832+	
30	Shaft-Short 17-4 PH	1	136833+	
32	Gear Key	1	200037000+	
33	Needle Roller Bearing	2	137553+	
34	Spacer, Bearing	2	137549+	
35	Four Point Angular Contact Brg.	4	137557+	
36	Cylindrical Roller Brg.	2	137561+	
37	Gear Case - Stainless Stl.	1	136844+	
38	Key .500 x .500 x 1.875	1	000037004+	
39	Nameplate - QR Code	1	135624+	
40	RHDS #2 x .125	4	30-355	
41	Breather Plug-Oil	1	115800+	
42	Gear Case Shim, SS (Mounting Foot)	1	102287+	
43	SHCS 1/2-13 x 2.0" 18-8	4	30-44	
44	Oil Sight Glass	1	137435+	
45	Plug-Drain/Level M20x1.5	2	137169+	
* 46	O-Ring Buna	2	N70114	
47	Plug 1/2" Plastic	2	000121001+	
48	Locking Nut	2	137569+	
49	Spacer-Gear	1	138981+	
50	Gear, Short Shaft, Spur	1	112105+	
51	Gear, Drive Shaft, Spur	1	110932+	
52	Locking Assembly	1	108786+	
53	BHSC Screw 6-32UNC .125 18-8 SS	4	139157+	
54	Shroud, Gear	2	139148+	
55	Cover, Gear Case	1	139001+	
56	Gasket, Gear Case/Cover	1	138522+	
57	Oil Seal, Gear Case Cover	1	STD030006	
58	Washer Plain 3/8 18-8 Narrow	6	43-30	
59	SHSB 1/2" X 1.0" 18-8	2	30-692	
60	HHCS 3/8-16 X .75 18-8 SS	6	30-50	

PL5060-CH146

Notes:

* Recommended spare parts

Universal Twin Screw Seal Parts

Items in a Double Mechanical Seal

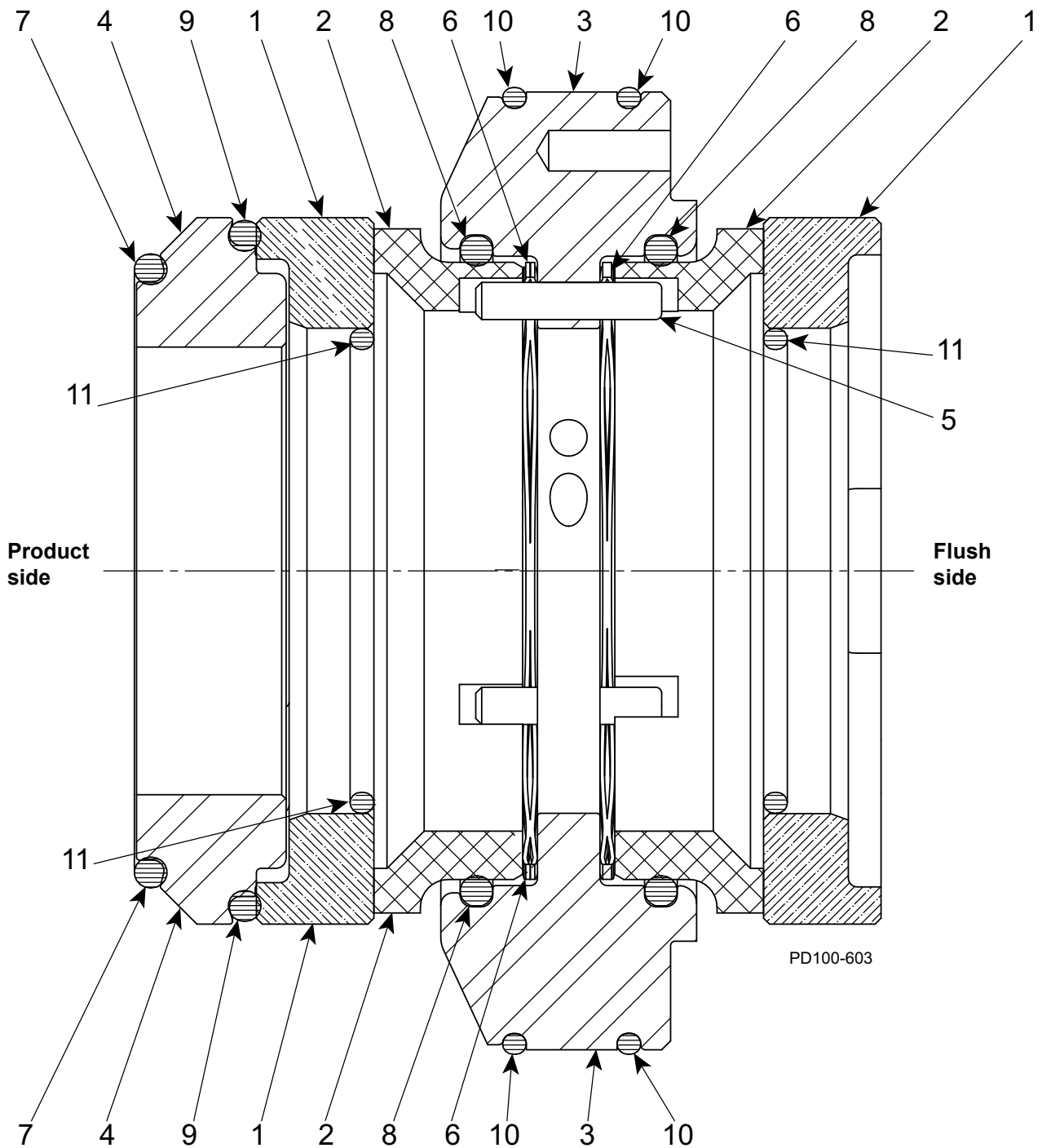

Items in a Single Mechanical Seal

Universal Twin Screw Seal Parts

Item No.	Description	Part Number				Qty., Double Mech. Seal	Qty., Single Mech. Seal	
		015-UTS	030-UTS	130-UTS	220-UTS			
1	Seat, Seal	SC	137104+	124745+	124747+	137106+	2	1
		TC	137105+	124746+	124748+	137107+		
2	Seal	C	137053+	137054+	137055+	137056+	2	1
		SC	137109+	137111+	137113+	137115+		
		TC	137110+	137112+	137114+	137116+		
3	Seal Carrier		137057+	137058+	137059+	137060+	1	1
4	Seal Cap		138878+	138879+	138880+	138881+	1	1
5	Pin, Stop		137076+	137077+	137078+	137079+	3	3
6	Seal Wave Spring		137015+	137016+	137017+	137018+	2	1
* 7	O-ring - Cap to Screw	EPDM	E70129	E70135	E70147	E70152	1	1
		FKM	V70129	V70135	V70147	V70152		
		FFKM	K70129	K70135	K70147	K70152		
* 8	O-ring - Carrier to Seal	EPDM	E70131	E70137	E70146	E70153	2	1
		FKM	V70131	V70137	V70146-680	V70153		
		FFKM	K70131	K70137	K70146	K70153		
* 9	O-ring - Cap to Seat	EPDM	E70131	E70138	E70147	E70153	1	1
		FKM	V70131	V70138	V70147	V70153		
		FFKM	K70131	K70138	K70147	K70153		
* 10	O-ring - Carrier to Body	EPDM	E70036	E70041	E70154	E70158	2	2
		FKM	V70036	V70041	V70154	V70158		
		FFKM	K70036	K70041	K70154	K70158		
* 11	O-ring - Shaft	EPDM	E70024	E70029	E70133	E70145	2	1
		FKM	V70024	V70029	V70133	V70145		
		FFKM	K70024	K70029	K70133	K70145		

PL5060-CH135

Note:

* Recommended Spare Parts

- Quantities listed are per seal assembly. There are two seal assemblies on each pump.
- The cross-sectional view on page 112 is of a double mechanical seal. Components of a single mechanical seal are called out in the bottom half of that image.

Special Tools

Non-Marring Socket Tool for Screw Nuts

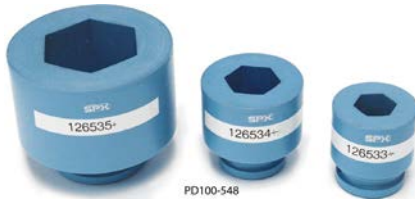

Pump Model	Part Number
015-UTS	126533+
030-UTS	126534+
130-UTS	126257+
220-UTS	126535+

PL5060-CH136

UTS Shaft Locking Tool

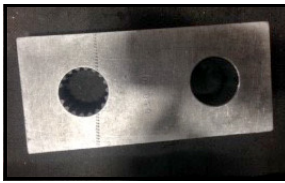

Pump Model	Part Number
015-UTS	139526+
030-UTS	139527+
130-UTS	139528+
220-UTS	139529+

PL5060-CH151

O-ring Removal Tool

Description	Part Number
O-ring removal tool	AD0096001

PL5060-CH130

Screw Blocking Tool

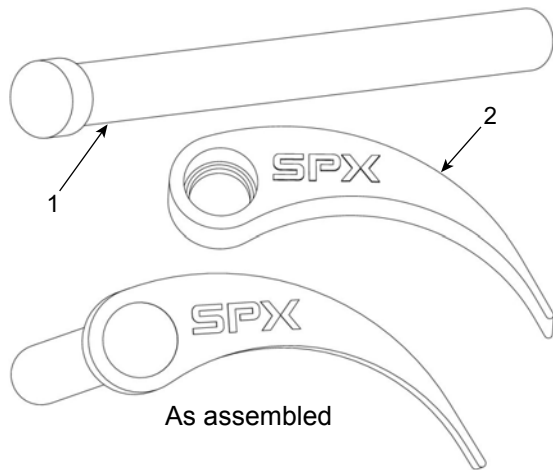

Item	Description	Part Number
1	Screw Blocking Dowel	139245+
2	Screw Wedge	139244+

PL5060-CH148

Gear Tools

Description	Pump Model	Part Number
Gear Nut Driver	015-UTS	109281+
Gear Nut Driver	030-UTS	109282+
Gear Nut Driver	130-UTS	109283+
Gear Nut Driver	220-UTS	110304+
Gear End Shaft Thread Chaser	015-UTS	109287+
Gear End Shaft Thread Chaser	030-UTS	109288+
Gear End Shaft Thread Chaser	130-UTS	109289+
Gear End Shaft Thread Chaser	220-UTS	110305+

PL5060-CH147

Notes

Universal Twin Screw Maintenance Summary Reference Sheet

Pump Model	Oil Capacity	Oil	Change oil
015-UTS	110 ml	Standard: Synthetic Mobil SHC 629-150, part no. 139215+ Food Grade: Synthetic Mobil SHC Cibus-150, part no. 139684+	250 hours, every 2000 hours thereafter*
030-UTS	216 ml		
130-UTS	525 ml		
220-UTS	1575 ml		

* Aggressive washdown or extreme running conditions may require more frequent intervals.

For more information, see "Lubrication" on page 26.

Pump Model	Torque Values - Locknuts		Wrench Size	
	Screw Nut	Cover Nut	Screw Nut	Cover Nut
015-UTS	12 ft-lb 16 N·m	7 ft-lb 10 N·m	15/16"	5/8"
030-UTS	38 ft-lb 52 N·m	11 ft-lb 15 N·m	1-1/4"	
130-UTS	88 ft-lb 119 N·m	25 ft-lb 34 N·m	1-5/8"	7/8"
220-UTS	200 ft-lb 271 N·m	55 ft-lb 75 N·m	2-1/4"	

Torque Values - Gear Case				
Pump Model	Bearing Retainer Screws	Locking Nut	Gear Case Cover Fasteners	
			HHCS	SHSB
015-UTS	24 in-lb (2 ft-lb) 3 N·m	15 ft-lb 20 N·m	88 in-lb 10 N·m	110 in-lb 12 N·m
030-UTS	84 in-lb (7 ft-lb) 9 N·m	30 ft-lb 41 N·m	110 in-lb 12 N·m	132 in-lb 15 N·m
130-UTS	180 in-lb (15 ft-lb) 20 N·m	45 ft-lb 61 N·m	132 in-lb 15 N·m	176 in-lb 20 N·m
220-UTS	300 in-lb (25 ft-lb) 34 N·m	75 ft-lb 102 N·m		

Torque Values - Locking Assembly				
Pump Model	Screw Hex Size	Qty.	Half Torque	Full Torque
015-UTS	5 mm	8	63 in-lb 7 N·m	126 in-lb 14 N·m
030-UTS	5 mm	6	79 in-lb 9 N·m	158 in-lb 18 N·m
130-UTS, 220-UTS	6 mm	6	189 in-lb 21 N·m	378 in-lb 43 N·m

Universal Twin Screw Maintenance Summary Reference Sheet - Copy for optional removal

Pump Model	Oil Capacity	Oil	Change oil
015-UTS	110 ml	Standard: Synthetic Mobil SHC 629-150, part no. 139215+ Food Grade: Synthetic Mobil SHC Cibus-150, part no. 139684+	250 hours, every 2000 hours thereafter*
030-UTS	216 ml		
130-UTS	525 ml		
220-UTS	1575 ml		

* Aggressive washdown or extreme running conditions may require more frequent intervals.

For more information, see "Lubrication" on page 26.

Pump Model	Torque Values - Locknuts		Wrench Size	
	Screw Nut	Cover Nut	Screw Nut	Cover Nut
015-UTS	12 ft-lb 16 N·m	7 ft-lb 10 N·m	15/16"	5/8"
030-UTS	38 ft-lb 52 N·m	11 ft-lb 15 N·m	1-1/4"	
130-UTS	88 ft-lb 119 N·m	25 ft-lb 34 N·m	1-5/8"	7/8"
220-UTS	200 ft-lb 271 N·m	55 ft-lb 75 N·m	2-1/4"	

Torque Values - Gear Case				
Pump Model	Bearing Retainer Screws	Locking Nut	Gear Case Cover Fasteners	
			HHCS	SHSB
015-UTS	24 in-lb (2 ft-lb) 3 N·m	15 ft-lb 20 N·m	88 in-lb 10 N·m	110 in-lb 12 N·m
030-UTS	84 in-lb (7 ft-lb) 9 N·m	30 ft-lb 41 N·m	110 in-lb 12 N·m	132 in-lb 15 N·m
130-UTS	180 in-lb (15 ft-lb) 20 N·m	45 ft-lb 61 N·m	132 in-lb 15 N·m	176 in-lb 20 N·m
220-UTS	300 in-lb (25 ft-lb) 34 N·m	75 ft-lb 102 N·m		

Torque Values - Locking Assembly				
Pump Model	Screw Hex Size	Qty.	Half Torque	Full Torque
015-UTS	5 mm	8	63 in-lb 7 N·m	126 in-lb 14 N·m
030-UTS	5 mm	6	79 in-lb 9 N·m	158 in-lb 18 N·m
130-UTS, 220-UTS	6 mm	6	189 in-lb 21 N·m	378 in-lb 43 N·m

Notes



Universal TS Series

ROTARY POSITIVE DISPLACEMENT
TWIN SCREW PUMP

SPXFLOW[®]

SPX FLOW, Inc.

611 Sugar Creek Road

Delavan, WI 53115

P: (262) 728-1900 or (800) 252-5200

F: (262) 728-4904 or (800) 252-5012

E: wcb@spxflow.com

SPX FLOW, Inc. reserves the right to incorporate our latest design and material changes without notice or obligation.

Design features, materials of construction and dimensional data, as described in this bulletin, are provided for your information only and should not be relied upon unless confirmed in writing.

Please contact your local sales representative for product availability in your region. For more information visit www.spxflow.com.

The green ">" is a trademark of SPX FLOW, Inc.

ISSUED: 06/2017

COPYRIGHT © 2017 SPX FLOW, Inc.