

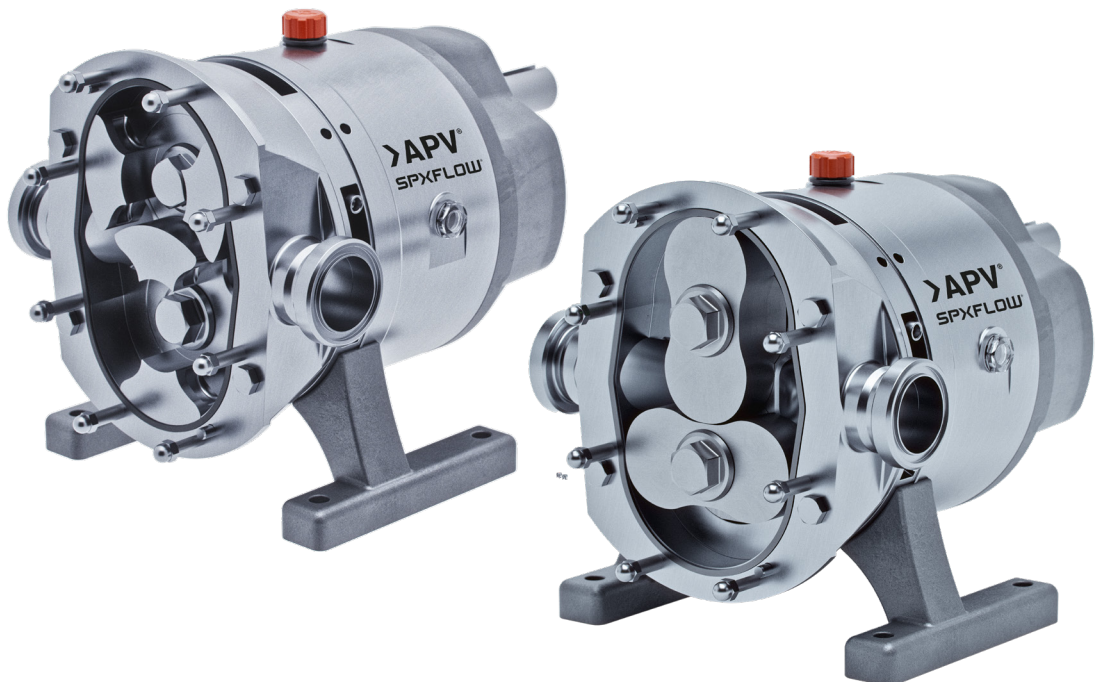

# DW+ POSITIVE DISPLACEMENT PUMP SERIES

Next generation of DW Pump Series



SPXFLOW®

# ENGINEERED FOR DURABILITY, EFFICIENCY, VERSATILITY, SAFETY.



**Discover the DW+ Series: the ultimate solution for efficiently pumping a wide range of high-value, high-viscosity products with minimal shearing. Elevate your operations today with next-generation performance.**

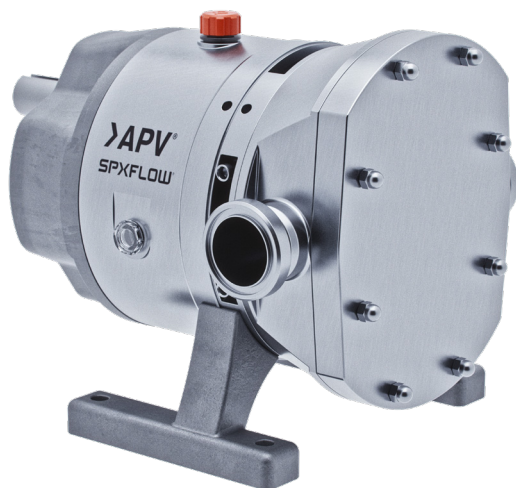

The APV DW+ Series represents the next generation in pump technology, offering powerful, reliable and efficient performance. Its piston design eliminates pulsation to protect downstream process equipment while integrating a pressure relief valve for enhanced safety.

## **Versatile Applications**

Engineered for a wide variety of applications, the DW+ Series excels in handling a range of viscosities from delicate creams, yogurt with fruit particles, shampoo, chocolate, ketchup and even dog food. It delivers consistent, high-quality output across diverse industries.

## **Robust Design for Durability**

DW+ pumps are positive-displacement, low-slip, stainless steel pumps built with larger-diameter shafts in duplex steel for greater strength and stiffness. Mounted on a stainless steel chassis, the pumps feature helical gears and double-tapered roller bearings for long-lasting reliability.

## **Less Shearing of Final Product**

Our non-galling alloy rotors maintain tight clearances and a long sealing path to minimize shearing, preserving the quality and integrity of high-value products. This ensures delicate formulations—such as food, pharmaceuticals, and cosmetics—retain their efficacy, texture and sensory attributes. By reducing processing damage, we help prevent quality issues, where changes in viscosity can impact texture and taste.

## **Pulse-Free Operation for System Protection**

Our unique piston rotor design ensures pulse-free operation when pumping highly viscous products. This reduces vibration and noise in the pipeline, prevents pressure surges, and protects valves and sensitive downstream equipment from potential damage. By maintaining a steady flow, the DW+ Series promotes seamless integration with equipment such as filling machines and ensures a consistent process flow, extending the lifespan of your equipment.

Trust the APV DW+ Series to deliver exceptional performance while safeguarding your product's quality and operational efficiency.

# POWERFUL, RELIABLE, EFFICIENT.

## TYPICAL APPLICATIONS



### BEVERAGES

Fruit Juices  
Cider and Wine  
Yeast  
Liquid Sugar and Glucose



### DAIRY PROCESSING

Cream, Milk  
Cheese Curd & Whey  
Cottage Cheese  
Yogurt



### FOOD

Fruit Preserves  
Soups and Sauces  
Baby Food  
Chocolates



### PHARMACEUTICAL/TOILETRIES

Antibiotics  
Toothpaste  
Cough Medicine  
Shampoo

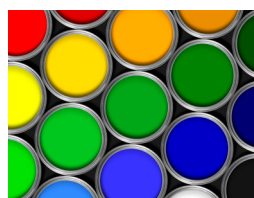

### CHEMICAL/INDUSTRIAL

Solvents, Paints, Fuels  
Resins, Polymers & Sludges  
Oil & Lubricants

### Gentle Product Handling

The rotor designs available ensure maximum product integrity and minimize risk of potential damage to sensitive products. Both piston and bi-lobe rotors are suitable for high and low viscosities. They also handle cheese curds and whey, soft fruit and meat — which previously involved fitting special rotors.

### High Volumetric Efficiency

The DW+ Series is designed for outstanding efficiency. Internal clearances have been minimized so that a smaller pump size can be selected for medium viscosity applications. This reduces both the initial investment and running costs.

### Ultra-Hygienic, Accommodates Harsh CIP-Cycles

All DW+ models are CIP/SIP cleanable, featuring a profiled front cover gasket for enhanced cleanability. Designed to withstand rapid temperature changes, these pumps handle very harsh CIP cycles.

### Low NPSH Requirements

The low NPSH requirement in combination with the absence of pressure pulsations makes the DW+ pumps ideal for many applications such as ultra-filtration and eliminating cavitation.

### Easy Maintenance

The easy-to-access front loaded mechanical seals reduce maintenance time considerably. All shaft seal O-rings are identical and access to the shaft seal is achieved by simply removing the front cover and the rotors. Likewise, the timing of rotors is an equally uncomplicated operation.

### Low Noise Level

The rotor design practically eliminates hydraulic noise and the helical gears minimize gearbox noise.

### Global Design

The DW+ Series is 3A approved and designed to EHEDG standards (certification to be issued 2025).

# ROBUST DESIGN - PISTON ROTOR EXAMPLE

**Enhance cleanability** with profiled front cover gasket

**Pulsation-free and low NPSHr performance** with unique piston rotors

**Reduced maintenance** with front-loaded mechanical seals

**Robust design** duplex steel shafts for greater strength and stiffness

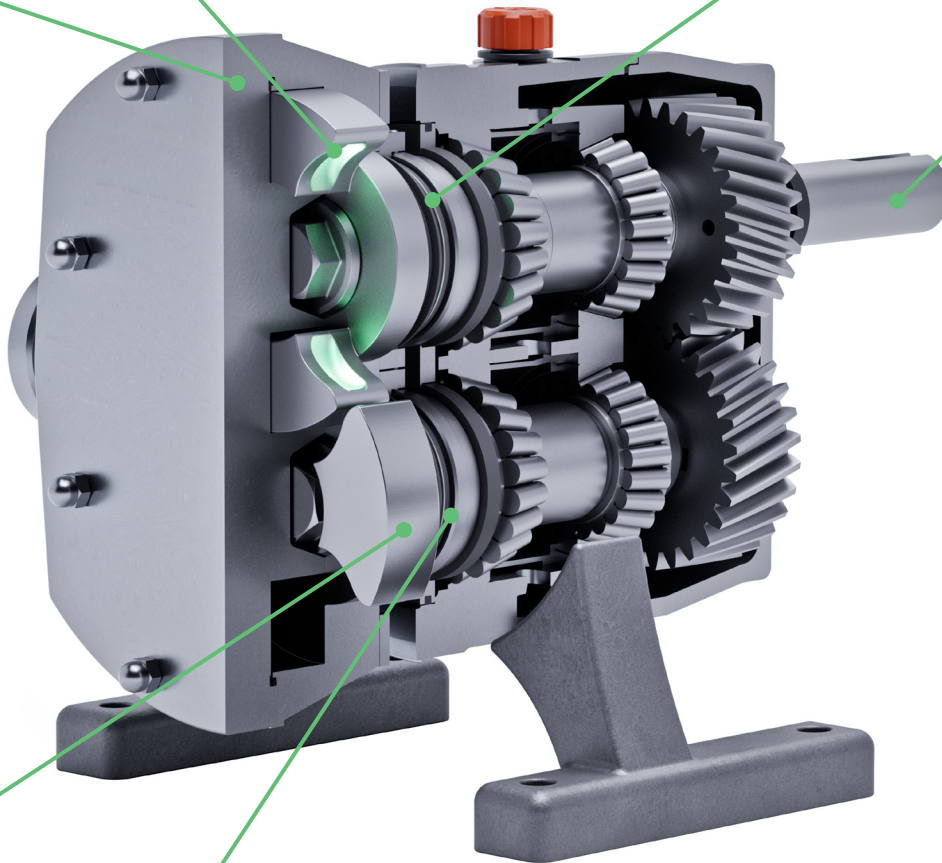

**Product integrity** non-galling alloy piston rotors maintain tight clearances and long sealing path to ensure less shearing of final product

**Flexible processing** with 6 different shaft seals for processing various products

**Lower energy consumption** high volumetric efficiency allows smaller motor

**Optimized flow** for improved efficiency, quieter operation, less vibration

Expanding cavities are formed at the inlet drawing the liquid into the rotors. Meshing of the rotors forces the fluid out of the pumping chamber.

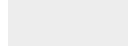
 Product  
 Empty Pump Cavity

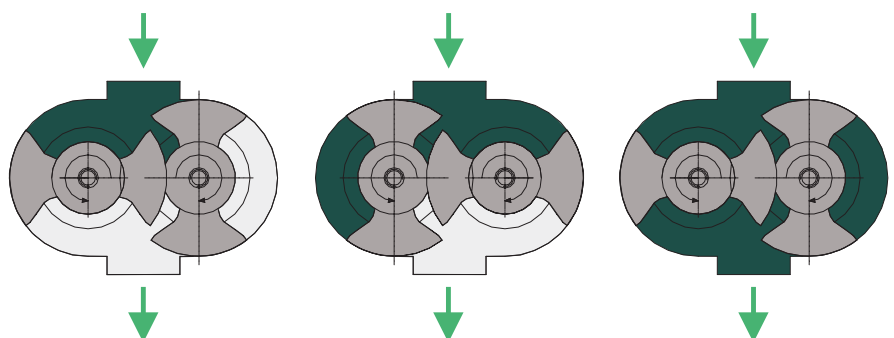

# OPTIONS



## Rectangular Inlet

Designed to handle high-viscosity products, the rectangular inlet ensures improved flow conditions by optimizing suction capability. This feature minimizes cavitation risks and enhances the pump's ability to handle very high viscous or difficult to flow products, such as processing meat efficiently, thereby ensuring consistent product delivery in demanding applications.



## Thermal Jacket

The thermal jacket is integral for maintaining the temperature of sensitive products like chocolate or syrups, preventing solidification and ensuring consistent viscosity for smooth operation. The thermal jacket is composed of two independent components, allowing for flexible selection based on needs: the thermal jacket casing, the thermal jacket front cover, or a combination of both.

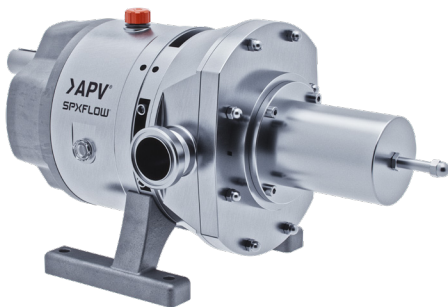

## Integrated Pressure Relief Valve

This safety feature automatically releases excess pressure within the pump, ensuring operational safety and protecting both the pump and associated equipment from potential damage. It ensures smooth operation in systems without the need for additional pressure-regulating devices or extra valves, improving reliability, reducing maintenance costs and maximizing system safety.



## Bi-lobe Rotors

These rotors are optimal for pumping fluids containing larger suspended solids. They provide gentle product handling, reduced internal cavitation and lower NPSH requirements. Additionally, their design ensures high volumetric efficiency and cost-effectiveness, making them suitable for a wide range of applications. The bi-lobe rotors can be supplied as high temperature rotors, suitable for product temperatures up to 180°C (356°F). The rotors are smaller for expansion due to the temperature.

# OPTIMAL PERFORMANCE

## Elastomer Material

EPDM, FPM and FKKM (perfluoroelastomer)

## Standard Connections

Tri-clamp is the standard connection. Other sanitary and industrial fittings are available.

## Two Rotor Options By Type

Piston and Bi-lobe rotors

## Four Rotor Options By Application

### 1. Multi Duty Rotors

Standard rotors suitable for most applications. The clearance is greater than that of the high efficiency rotors.

### 2. High Efficiency Rotors

Designed for low viscosity products. The size of the rotors has been increased and the clearance is minimal.

### 3. Non Galling Alloy (NGA) Rotors

Are made of Non Galling Alloy (W88) for use with low viscosity products. The material allows the rotors to touch the pump housing without damaging the housing or the rotors. Low tolerances may therefore be applied without decreasing the reliability.

### 4. High Temperature Rotors

The bi-lobe rotors can be supplied as high temperature rotors, suitable for product temperatures up to 180°C (356°F). The rotors are smaller for expansion due to the temperature.



Choose from a range of rotor options for optimal performance. Select either a single mechanical seal for general use or a double seal for abrasive substances, with flushing water protection. Additional options like lip seals or packed gland seals offer on-site convenience and flexibility.



Piston Type Rotor

Lobe Type Rotor

	DESIGN			FEATURES			
ROTOR TYPES BY APPLICATION	MATERIAL	CLEARANCE	ROTOR TYPES	MAX. OPERATING TEMPERATURE	FULLY POSITIVE	MAX. DIFFERENCE IN PRESSURE (% OF PUMP MAXIMUM)	VULNERABILITY TOWARDS FOREIGN MATTER BIGGER THAN CLEARANCE
HIGH TEMPERATURE	316L	LARGE	BI-LOBE	180°C (356°F)	700 CP	100%	LOW
HIGH TEMPERATURE	NGA	LARGE	BI-LOBE	180°C (356°F)	700 CP	100%	LOW
MULTI DUTY	316L	MEDIUM	PISTON OR BI-LOBE	110°C (230°F)	500 CP	100%	HIGH
HIGH EFFICIENCY	316L	SMALL	PISTON OR BI-LOBE	110°C (230°F)	300 CP	100%	HIGH
HIGH EFFICIENCY	NGA	SMALL	PISTON OR BI-LOBE	110°C (230°F)	300 CP	100%	HIGH
SUPER TIGHT	NGA	VERY SMALL	PISTON OR BI-LOBE	110°C (230°F)	100 CP	80%	LOW

# VERSATILITY AND PRECISION



			MAXIMUM DISPLACEMENT	MAXIMUM PRESSURE
MODEL NUMBER	MAX SPEED (RPM)	ROTOR TYPE	LITERS/100 REVS (GAL/100 REVS)	BAR (PSI)
DW+1/003/7.5	1400	PISTON	3 (0.8)	7.5 (109)
DW+2/006/10	1400	PISTON	6 (1.6)	10 (145)
DW+3/014/10	1400	PISTON	14 (3.7)	10 (145)
DW+4/033/10	1200	PISTON	33 (8.7)	10 (145)
DW+5/080/12.5	1000	PISTON	80 (21.1)	12.5 (181)
*DW6/172/12.5	800	PISTON	172 (45.4)	12.5 (181)

6 Models. \*DW6 model stays with original DW design.



			MAXIMUM DISPLACEMENT	MAXIMUM PRESSURE
MODEL NUMBER	MAX SPEED (RPM)	ROTOR TYPE	LITERS/100 REVS (GAL/100 REVS)	BAR (PSI)
DW+1/004/15	1400	BI-LOBE	4 (1.1)	15 (218)
DW+1/007/7	1400	BI-LOBE	7 (1.8)	7 (102)
DW+1/007/15	600	BI-LOBE	7 (1.8)	15 (218)
DW+2/007/20	1400	BI-LOBE	7 (1.8)	20 (290)
DW+2/013/10	1400	BI-LOBE	13 (3.4)	10 (145)
DW+2/013/15	600	BI-LOBE	13 (3.4)	20 (290)
DW+3/017/20	1400	BI-LOBE	17 (4.5)	20 (290)
DW+3/030/10	1400	BI-LOBE	30 (7.9)	10 (145)
DW+3/030/15	600	BI-LOBE	30 (7.9)	15 (218)
DW+3/050/5	1400	BI-LOBE	50 (13.2)	15 (218)
DW+4/0039/20	1200	BI-LOBE	39 (10.3)	20 (290)
DW+4/073/10	1200	BI-LOBE	73 (19.3)	10 (145)
DW+4/073/15	600	BI-LOBE	73 (19.3)	15 (218)
DW+4/125/5	1200	BI-LOBE	125 (33.0)	5 (73)
DW+4/125/7	600	BI-LOBE	125 (33.0)	7 (102)
DW+5/093/25	1000	BI-LOBE	93 (24.6)	25 (363)
DW+5/142/15	1000	BI-LOBE	142 (37.5)	15 (218)
DW+5/256/7	1000	BI-LOBE	256 (67.6)	7 (102)
*DW6/198/30	800	BI-LOBE	198 (52.3)	30 (435)
*DW6/308/15	800	BI-LOBE	308 (81.4)	15 (218)
*DW6/519/7	800	BI-LOBE	519 (137.1)	7 (102)

21 Models. \*DW6 models stays with DW design

The DW+ pump series is designed for ultra-hygienic applications. The range consists of 6 sizes (27 models) with capacities ranging from 3 liters/100 revs to 519 liters /100 revs (0.8 gal/100 revs to 137 gal/100 revs) and pressures up to 30 bar (435 psi). All product-contact parts are made from AISI 316L stainless steel and all elastomers comply with FDA-requirements.

There are two types of rotors available: piston and bi-lobe. For general or standard applications, the bi-lobe rotor is typically a suitable solution. However, the piston rotor is the optimal choice for shear-sensitive products due to its long sealing path and minimal clearance design.

Another benefit is interchangeability. On the smallest model in each size, the piston rotors can be easily replaced with bi-lobe rotors without altering the rotor case. Additionally, the pump's porting can be switched between horizontal and vertical orientations (and vice versa) without requiring any modifications to the pump or the use of a specialized gear case assembly.



The figures included in this brochure are for guidance only. Please use the DW+ Pump Sizing program or contact your local SPX FLOW office for sizing and help selecting a DW+ Pump.



Your contact for **sales & service:**

**AxFlow GmbH** Germany & Switzerland · 40472 Düsseldorf, Germany · 4132 Muttenz, Switzerland  
www.axflow.de · www.axflow.ch · info@axflow.de · Tel. +49 211 23806-0



SPX FLOW, Inc. reserves the right to incorporate our latest design and material changes without notice or obligation. Design features, materials of construction and dimensional data, as described in this bulletin, are provided for your information only and should not be relied upon unless confirmed in writing. Please contact your local sales representative for product availability in your region. The green " " is a trademark of SPX FLOW, Inc.

For more information, visit [www.spxflow.com](http://www.spxflow.com).